



## Double Workholding System DUO

clamping against the central fixed jaw, mechanically operated  
 jaw width 80 mm



### Advantages

- Compact design
- Highest position and repetitive accuracy
- with 3rd-hand function
- Extensive range of jaws
- Easy to maintain

### Technical data

Clamping principle: **clamping against the central fixed jaw mechanically**  
 Operation: with a torque wrench

#### DUO 80 / 200

Length of the base: 200 mm  
 Jaw width: 80 mm  
 Clamping force\*: 12 kN at 50 Nm  
 Max. jaw opening: 2 x 93 mm

#### DUO 80 / 240

Length of the base: 240 mm  
 Jaw width: 80 mm  
 Clamping force\*: 12 kN at 50 Nm  
 Max. jaw opening: 2 x 115 mm

### Application

Double workholding systems DUO are particularly suitable for double clamping - both in horizontal and vertical plane.

### Accessories

- Clamping jaws and jaw inserts, accessories for mounting, positioning and operation see data sheet WS 3.380Z

### Application example

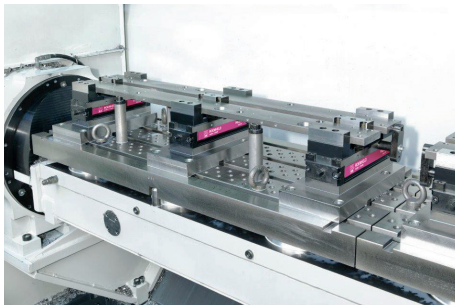

Double workholding system DUO

### Description

Double clamping systems DUO convince by their short overall length, durability and precision. The guidance and sealing principle works without any delicate sheet metal covers or plastic wipers. The centrally arranged fixed jaw as a central jaw is without load and thus absolutely zero point stable.

The workpieces are positioned close to each other, and thus reducing the travel paths of the machining centre to a minimum. The purely mechanical operation enables clamping also with low and always reproducible clamping forces.

These characteristics turn the double workholding systems DUO into a flexible standard fixture for a wide variety of applications in modern production.

For double workholding systems DUO, a wide range of clamping jaws is available (see data sheet WS 3.380Z).

### Customised versions

Double workholding systems DUO can also be delivered as customised versions. For example with individual fixing holes or special jaws. Please contact us.

### Consultation

Our experts will be pleased to advise you also on site, and work with you to find the optimum clamping solution.

Extensive information such as drawings and CAD models are available on request.

### Functional description

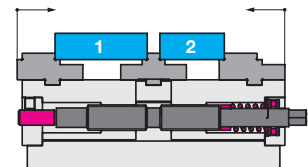

Mechanical double workholding system with spindle drive

### Versions

#### Mechanically operated

The two movable jaws are guided to the central fixed jaw via a right-left threaded spindle. An integrated pre-clamping system (3rd hand function) holds the workpiece inserted first in its position, while the second workpiece is positioned. With this function, the clamping stroke varies between 12 – 14 mm (DUO 80 / 200) and 48 – 50 mm (DUO 80 / 240). The joint and uniform clamping force build-up can then take place.

#### \*Important note

The specified clamping forces apply to a clamping height (n) of 16 mm. For higher clamping heights, the clamping forces are reduced.

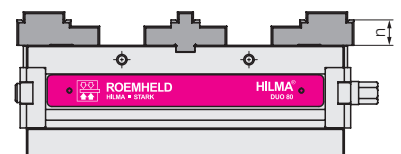

# Technical data Dimensions

## DUO 80/200

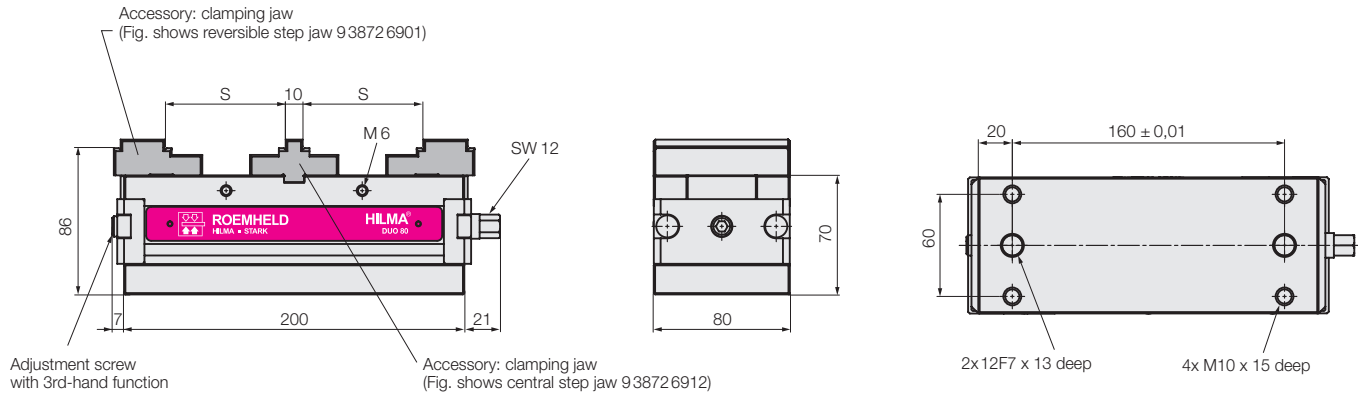

## DUO 80/240

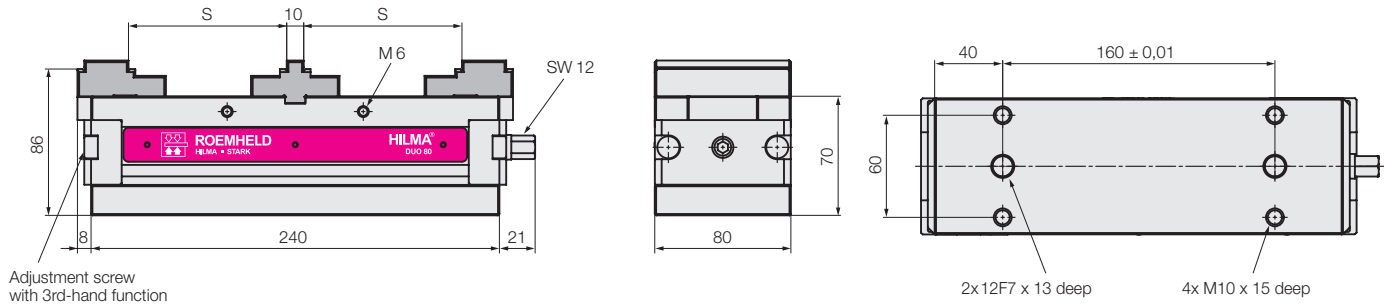

All dimensions in [mm]

Series	DUO 80/200	DUO 80/240
Size	200	240
Clamping principle	clamping against the central fixed jaw	clamping against the central fixed jaw
Operation	mechanical	mechanical
Clamping force / torque [kN/Nm]	12/50	12/50
Repetitive clamping accuracy [mm]	±0.01	±0.01
Clamping range S <sup>1)</sup> [mm]	6 – 93	0 – 115
Weight without clamping jaws [kg]	7.1	8.4
Part no. without clamping jaws	938720101	938720201

<sup>1)</sup> depending on the used clamping jaw