

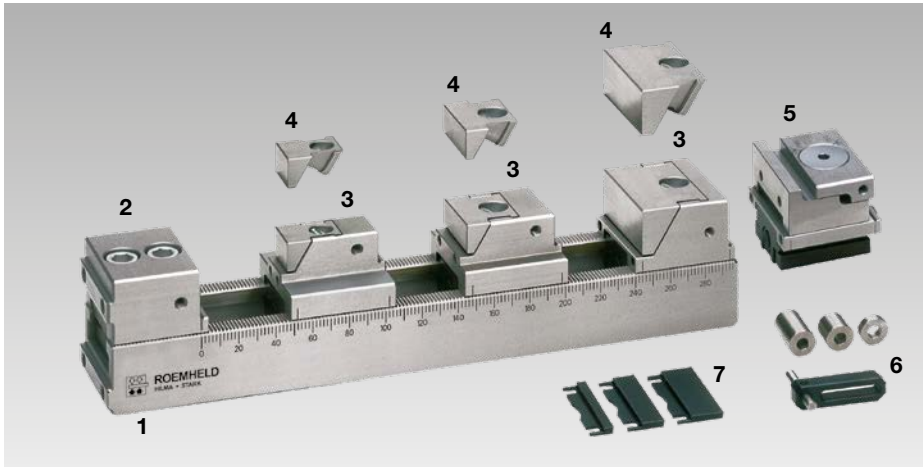

Multiple Workholding Systems MSH

clamping against the fixed jaw, mechanically operated
 jaw widths 24 to 120 mm, versions: Premium, EasyClamp, Goliath



Advantages

- High flexibility due to the modular design
- Fixed and clamping modules are available in various width
- Any extension to the base modules is possible
- Short set-up times
- Precise frictional connection between base and clamping module via fine toothing
- Patented eccentric clamping by means of one fixing screw only
- Accommodation of a maximum number of workpieces

Insert

The high-precision multiple workholding system MSH clamps cubic workpieces with identical or different dimensions in small, medium and large lot sizes.

The multiple workholding system MSH may be used as an individual system or in combination with additional elements (e.g. towers, bridges, base plates) on all machine tools, machining centres and flexible manufacturing systems.

Design

The multiple workholding system MSH consists of modular elements (see picture above)

1. Base module
2. Fixed module
3. Pull-down clamping modules
4. Clamping jaws
5. Linear clamping module
6. Stops
7. Workpiece supports
8. Torque wrench

Versions

Premium

Highest precision in series

- all faces grounded
- tolerance ± 0.01 mm
- all system parts hardened and corrosion-resistant
- clamping modules with retaining guide
- scale on both sides

EasyClamp

For lower-cost introduction

- all surfaces fine milled and surface hardened
- tolerance ± 0.03 mm
- scale one-sided
- eccentric lead screw with hexagon socket

Goliath

Clamping modules for high requirements

- clamping forces up to 40 kN per element
- additional force absorption with link blocks
- use at heavy-duty machining

All clamping series are compatible and can be combined with each other!

Consultation

Our experts will be pleased to advise you also on site, and work with you to find the optimum clamping solution.

Extensive information such as drawings and CAD models are available on request.

Set-up



1. The clamping module with released eccentric locking is inserted in the slot.



2. The clamping module is exactly positioned on the base module using the graduation marks and the scale.



3. The clamping module is fixed by means of the eccentric screw and the torque wrench.

Application example



Dimensions

Base modules • Fixed modules

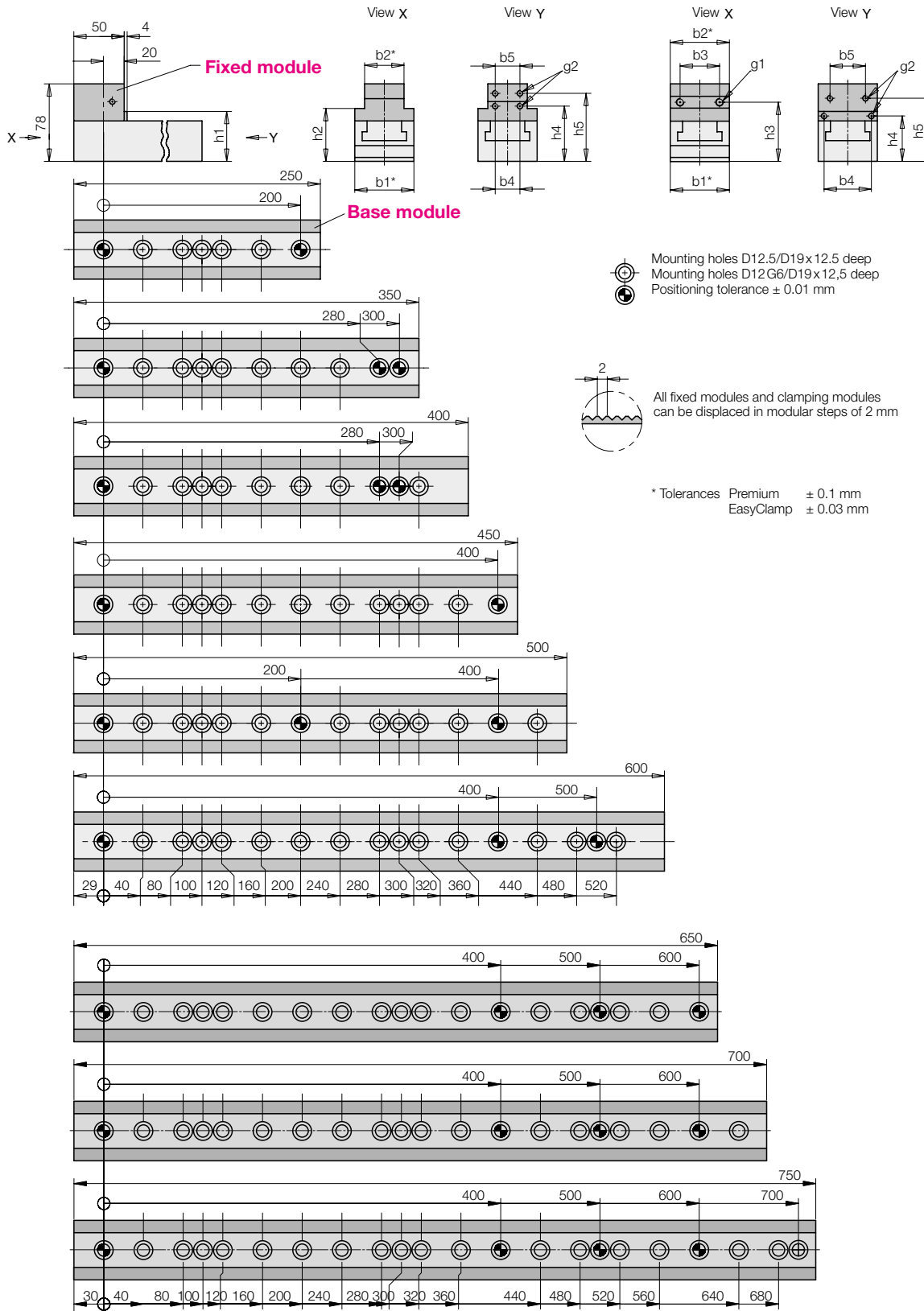

Module width	Jaw width	Height of support										
b1	b2	h1	b3	b4	b5	h2	h3	h4	h5	g1	g2	
60	24	60	–	13	–	55.5	–	54	–	–	M5/ 6 deep	
60	40	60	–	25	25	55.5	–	56	69	–	M6/ 8 deep	
60	60	50	40	48	36 (30*)	–	60	46	64	M8/12 deep	M6/10 deep	
100	100	50	40	80	60	–	60	46	64	M8/12 deep	M6/10 deep	

Dimensions in [mm]

Par numbers
Base modules • Fixed modules

Base modules

Module width b1 [mm]	Jaw width b2 [mm]	Length L [mm]	Premium	EasyClamp	Goliath
			Part no.	Part no.	Part no.
60	–	250	93481 0625	93491 0625	↑ Use premium base modules! ↓
100	–	250	93481 1025	93491 1025	
60	–	350	93481 0635	93491 0635	
100	–	350	93481 1035	93491 1035	
60	–	400	93481 0640	93491 0640	
100	–	400	93481 1040	93491 1040	
60	–	450	93481 0645	93491 0645	
100	–	450	93481 1045	93491 1045	
60	–	500	93481 0650	93491 0650	
100	–	500	93481 1050	93491 1050	
60	–	600	93481 0660	93491 0660	
100	–	600	93481 1060	93491 1060	
60	–	650	93481 0665	93491 0665	
100	–	650	93481 1065	93491 1065	
60	–	700	93481 0670	93491 0670	
100	–	700	93481 1070	93491 1070	
60	–	750	93481 0675	93491 0675	
100	–	750	93481 1075	93491 1075	

Special lengths up to 1000 mm on request

Fixed modules

Module width b1 [mm]	Jaw width b2 [mm]	Length L [mm]	Part no.	Part no.	Part no.
60	24		93482 1100	–	–
60	40		93482 2100	93492 2100	–
60	60		93482 3100	93492 3100	93482 5100
60	60	Linear clamping module	93482 3300	–	–
100	100		93482 4100	93492 4100	93482 6100
120	120		–	–	93482 7100

Dimensions in [mm]

Technical data • Dimensions

Clamping modules

Pull-down clamping modules

Max. clamping force:
17 kN at 17 Nm

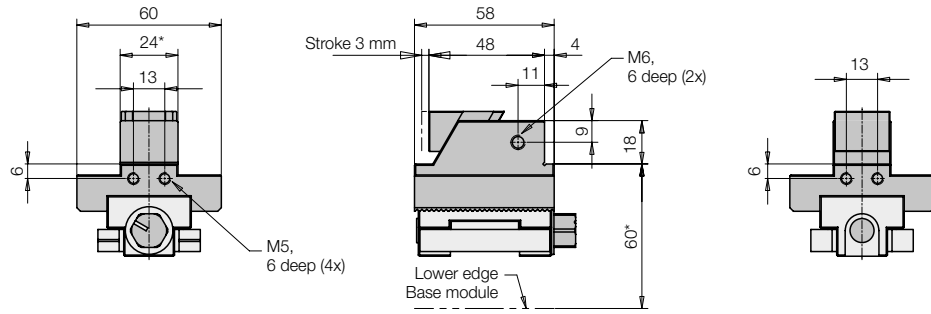

Max. clamping force:
20 kN at 20 Nm

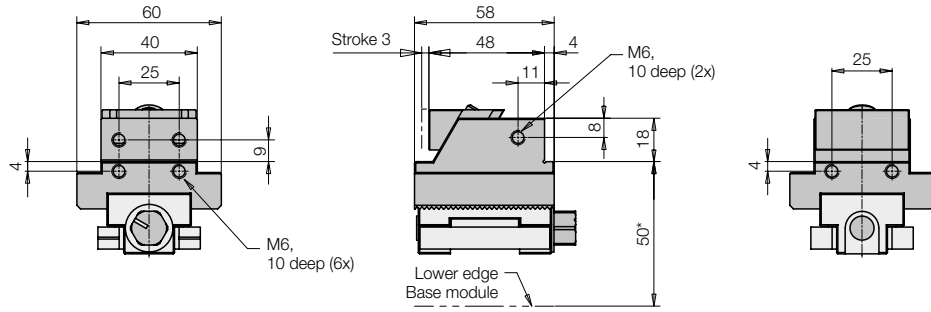

Max. clamping force:
25 kN at 25 Nm

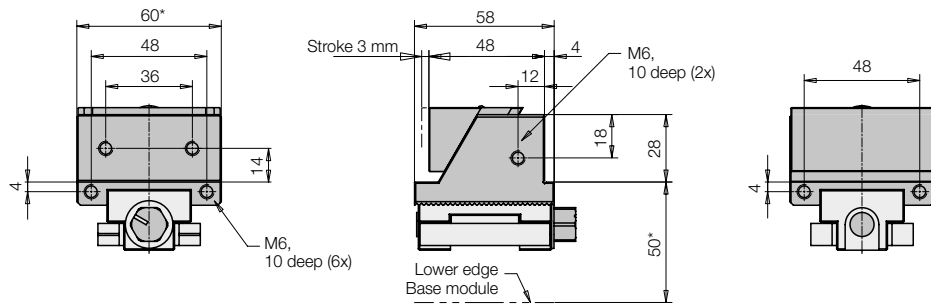

Max. clamping force:
25 kN at 25 Nm

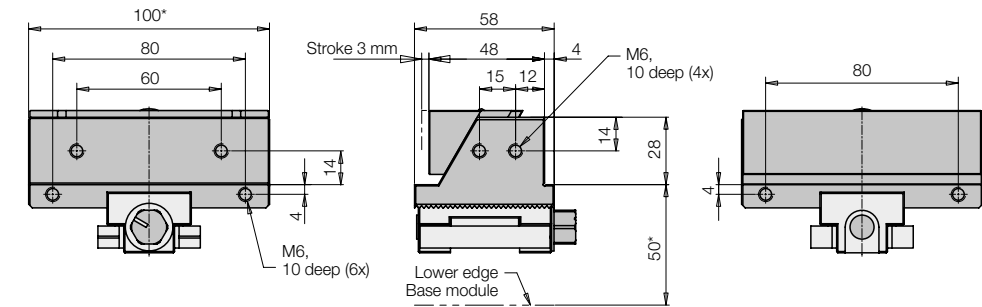

* Tolerances Premium ± 0.01 mm / EasyClamp ± 0.03 mm

Linear clamping modules

Max. clamping force:
15 kN at 30 Nm

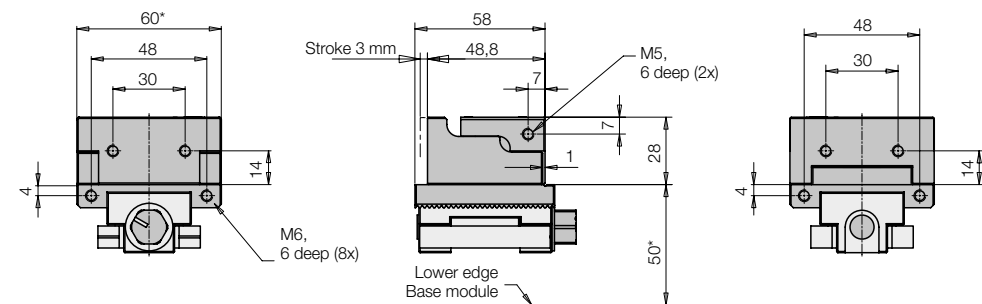

Technical data • Dimensions • Part numbers

Clamping modules

Goliath pull-down clamping modules

Max. clamping force:
35 kN at 40 Nm

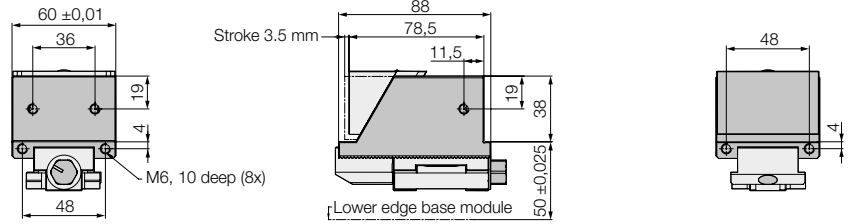

Max. clamping force:
35 kN at 40 Nm

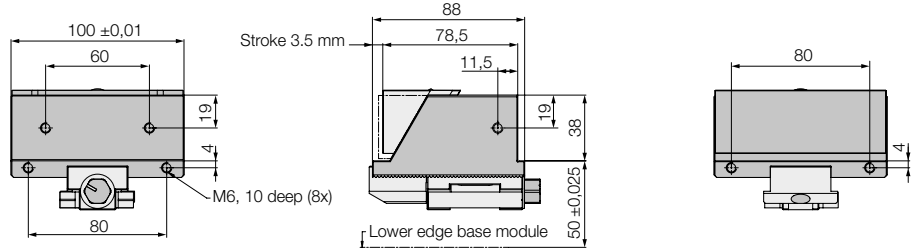

Max. clamping force:
40 kN at 65 Nm

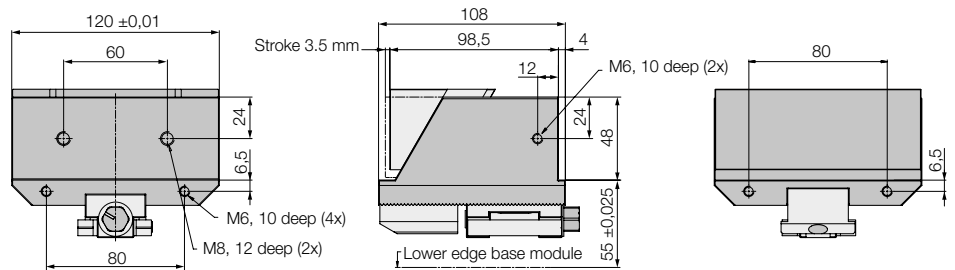

Pull-down clamping modules incl. clamping jaw

Module width b1 [mm]	Jaw width b2 [mm]	Clamping jaw type	Premium	EasyClamp	Goliath
			Part no.	Part no.	Part no.
60	24	smooth	93483 1110	-	-
60	24	serrated	93483 1120	-	-
60	40	smooth	93483 2110	93493 2110	-
60	40	serrated	93483 2120	93493 2120	-
60	60	smooth	93483 3110	93493 3110	93483 5110
60	60	serrated	93483 3120	93493 3120	93483 5120
100	100	smooth	93483 4110	93493 4110	93483 6110
100	100	serrated	93483 4120	93493 4120	93483 6120
120	120	smooth	-	-	93483 7110
120	120	serrated	-	-	93483 7120

Linear clamping modules

Module width b1 [mm]	Jaw width b2 [mm]	Clamping jaw type	Part no.	Part no.	Part no.
60	60	smooth	93483 3210	-	-
60	60	serrated	93483 3220	-	-

Single clamping jaws

Module width b1 [mm]	Jaw width b2 [mm]	Clamping jaw type	Part no.	Part no.	Part no.
	24	smooth	93484 1110	-	-
	24	serrated	93484 1120	-	-
	40	smooth	93484 2110	93494 2110	-
	40	serrated	93484 2120	93494 2120	-
	60	smooth	93484 3110	93494 3110	93484 5110
	60	serrated	93484 3120	93494 3120	93484 5120
for linear clamping module	60	smooth	93484 3210	-	-
for linear clamping module	60	serrated	93484 3220	-	-
	100	smooth	93484 4110	93494 4110	93484 6110
	100	serrated	93484 4120	93494 4120	93484 6120
	120	smooth	-	-	93484 7110
	120	serrated	-	-	93484 7120

Accessories

Workpiece supports

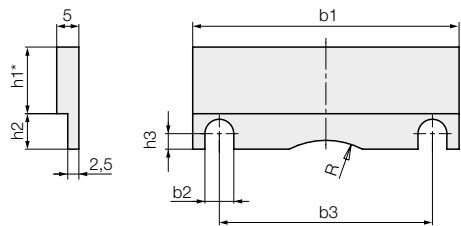

* Tolerance:
± 0.05 mm soft steel + aluminium
± 0.01 mm hardened steel

Part no.	Jaw width b1	Height h1	Type	b2	b3	h2	h3	h4	R
xx1	24	from 3 to 18	soft steel	5.5	13	11	6.75	-	-
934851xx2		from 3 to 15	hardened steel						
xx3		from 3 to 18	aluminium						
xx1	40	from 3 to 18	soft steel	6.5	25	11	6.75	-	-
934852xx2		from 3 to 15	hardened steel						
xx3		from 3 to 18	aluminium						
xx1	60	from 6 to 28	soft steel	6.5	48	8.5	5.25	2	18
934853xx2		from 6 to 25	hardened steel						
xx3		from 6 to 28	aluminium						
xx1	100	from 6 to 28	soft steel	6.5	80	8.5	5.25	2	18
934854xx2		from 6 to 25	hardened steel						
xx3		from 6 to 28	aluminium						

Height h1 (in steps of 1 mm):
xx - 03 - for 3 mm
xx - 28 - for 28 mm

Torque wrench

8 – 40 Nm for clamping/unclamping
incl. socket SW 5, 6, 8, 10 (interior)
(for Goliath on request)



Part no. 937926650

Torque wrench

65 Nm, to fix the clamping module
incl. socket SW 14 (exterior)



Part no. 937926660

Stop

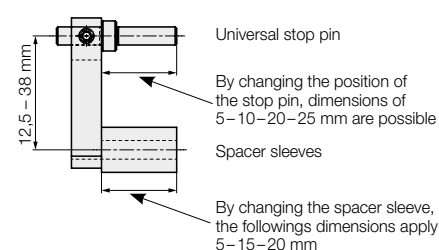

Part no. 934880100

Spacer jaws

They are required for jaw openings < 10 mm and screwed onto the fixed side of the clamping module.

Jaw width 24 mm

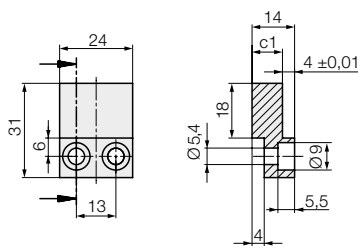

Jaw width 40 – 100 mm

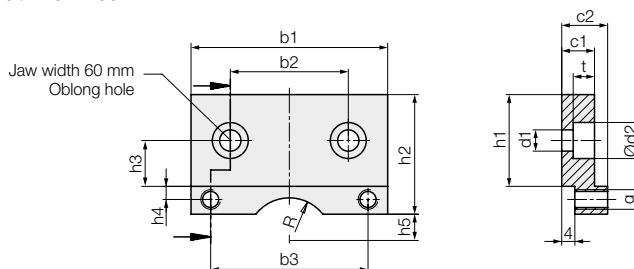

Jaw width b1 [mm]	Type	b2	b3	c1 ±0.01	c2	d1	d2	g	h1	h2	h3	h4	h5	R	t	Part no.	
24	soft steel	smooth	-	13	10	Dimensions see drawing										934861110	
	hardened steel	smooth				934861160											
		serrated				934861170											
40	soft steel	smooth	25	25	10	14	6.5	11	M6	18	31	9	4	-	-	6.5	934862110
	hardened steel	smooth															934862160
		serrated															934862170
60	soft steel	smooth	30	48	10	14	6.5	11	M6	28	36.5	14	4	8	13	6.5	934863110
	hardened steel	smooth															934863160
		serrated															934863170
100	soft steel	smooth	60	80	10	14	6.5	11	M6	28	36.5	14	4	8	13	6.5	934864110
	hardened steel	smooth															934864160
		serrated															934864170

Formed jaws (soft steel or aluminium) for milling workpiece contours on request.