

## MC-P Clamping systems

### Jaw widths 40 mm, Fixed jaw - mechanical

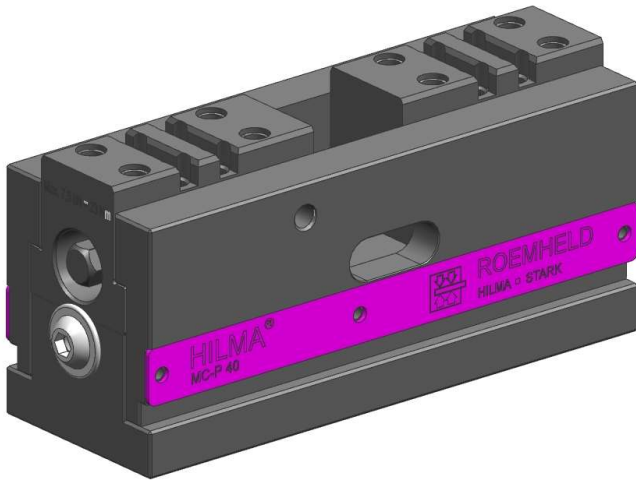

### 1 Product description

#### Description

The products are designed for multi-purpose workpiece clamping on machine tools.

The clamping force is applied by rotating the spindle clockwise by means of a torque wrench.

#### Application

The products are used for processing dimensionally stable workpieces in single or multiple clamping systems.

The products are suitable both for series production and individual production.

### 2 Documentation applicability

This documentation is applicable to the following products:

Products of catalogue sheet WS 5.4501. These cover the types and/or order numbers:

- 9.4581.0101

### 3 Target group

Specialist staff, fitters and set-up staff of machines and systems with expert knowledge of hydro-mechanical equipment.

#### Staff qualification

Expert knowledge means, that staff must:

- be capable to read and completely understand technical specifications such as circuit diagrams and product-specific drawings;
- have expert knowledge of the function and construction of the relevant components.

An **expert** is a person who has sufficient knowledge based on professional training and experience and who is familiar with the relevant standards and regulations, so that he/she:

- may assess the work assigned to him/her;
- is able to identify potential risks;
- is able to take appropriate measures to eliminate risks;
- is aware of the approved technical standards, codes and regulations;
- has the required knowledge for repair and installation.

### Contents

1	Product description .....	1
2	Documentation applicability .....	1
3	Target group.....	1
4	Symbols and signal words.....	2
5	For your safety .....	2
6	Use .....	2
7	Assembly .....	3
8	Start-up.....	3
9	Operation.....	4
10	Maintenance .....	5
11	Troubleshooting .....	5
12	Technical data .....	6
13	Disposal .....	6
14	Installation statement .....	7

## 4 Symbols and signal words

### **WARNING**

#### Personal injury

Identifies a potentially hazardous situation.

If not avoided, death or serious injuries may be the consequence.

### **CAUTION**

#### Light injuries / damage to property

Identifies a potentially hazardous situation.

If not avoided, light injuries or damage to property may be the consequence.

#### Hazardous to the environment



This symbol identifies important information for the proper handling of substances which are hazardous to the environment.

Non-compliance with the related instructions may result in serious environmental damage.



#### Mandatory action symbol!

This symbol identifies important information of required protection equipment, etc.

### **NOTE**

- This symbol identifies tips for application or particularly useful information. It is not a signal word for dangerous or hazardous situations.

## 5 For your safety

### 5.1 General information

This Operation Manual is intended to provide information on and avoidance of risks related to the installation of the products into the machine, as well as information and notes on transport, storage and maintenance.

Accidents and damage to property can only be avoided and the trouble-free operation of the products can only be guaranteed if this Operation Manual is strictly observed.

In addition, compliance with this Operation Manual will help to:

- avoid injuries;
- reduce downtimes and repair cost;
- increase the products' lifetime.

### 5.2 Safety instructions

The product was manufactured in accordance with the generally recognized codes of practice.

Please observe the safety instructions and procedural descriptions in this Operation Manual in order to avoid personal injuries or damage to property.

- Please read this Operation Manual carefully and completely before working with the product.
- Please keep this Operation Manual where it is accessible to all product users at any time.
- Please observe the applicable safety instructions as well as instructions for the prevention of accidents and for environmental protection in the country where the product is used.
- Please only use this Roemheld product in a technically safe and perfect condition.
- Please observe all instructions on the product.

- Please only use accessories and spare parts approved by the manufacturer in order to exclude personal risks due to unsuitable spare parts.
- Please only use the product in accordance with its intended purpose.
- You may only start operation with the product if it has been determined that the incomplete machine and/or the machine in which the product is to be installed complies with the country-specific regulations, safety instructions and standards.
- Please perform a risk analysis for the incomplete machine and/or machine.  
Interactions between the product and the machine/system and its environment may result in risks, which may only be identified and minimized by the user, e.g.:
  - forces generated;
  - movements initiated;
  - influence of hydraulic and electrical controls;
  - etc.
- Use of personal protection equipment is to be considered for all work steps.

## 6 Use

### 6.1 Use in compliance with intended purpose

The products are exclusively designed for clamping workpieces in industrial applications.

In addition, use in compliance with the intended purpose includes:

- Use within the capacity limits specified in the technical data (see catalogue sheet).
- Use as described in this Operation Manual.
- Compliance with maintenance intervals.
- Assignment of staff qualified or trained in the relevant activities.
- Installation of spare parts with the same specifications as the original parts only.
- Only clamping jaws may be moved.

### 6.2 Improper use

#### **WARNING**

##### Injuries, damage to property or malfunction!

- Do not modify the product!

Use of products is impermissible:

- for domestic applications.
- on pallets or tool tables in prototype or forming machines.
- if the products or gaskets might be damaged by physical/chemical effects (vibrations, welding currents or others).
- in machines, pallets or tool tables used for modifying the material properties (magnetizing, radiation, photochemical processes, etc.).
- in areas subject to special regulations, in particular as regards systems and machines:
  - for use on funfairs and in amusement parks.
  - for use in food processing or in areas subject special hygienic regulations.
  - for military purposes.
  - in mines.
  - in explosive and aggressive environments (e.g. ATEX).
  - in medical engineering.
  - in aerospace engineering.
  - for passenger transportation.

- if deviating operating and environmental conditions apply, e.g.:
  - if operating pressures exceed those indicated in the catalogue sheet and/or the installation drawing.
  - if pressure liquids not complying with the specified ones are used.
  - if volume flows exceed those indicated in the catalogue sheet and/or the installation drawing.

**Special solution models are available upon request!**

## 7 Assembly

### **WARNING**

#### Injuries by parts falling off!

- Keep hands and other parts of the body remote of the working area.
- Wear personal protection equipment!

### **CAUTION**

#### Heavy weigh may drop

- Some product types have a significant weight. These products have to be secured against dropping during transport.
- Weight data are included in the "Technical data" section.

### **NOTE**

#### Aggressive media

If there is a possibility that aggressive cutting and cooling liquids including chippings may ingress the inside of the clamping slide, the clamping slide inside must be cleaned by the customer.

#### Ease of movement

Please make sure that the product moves easily upon installation!

### 7.1 Design

The mechanical force is transferred to the jaws via the slide.

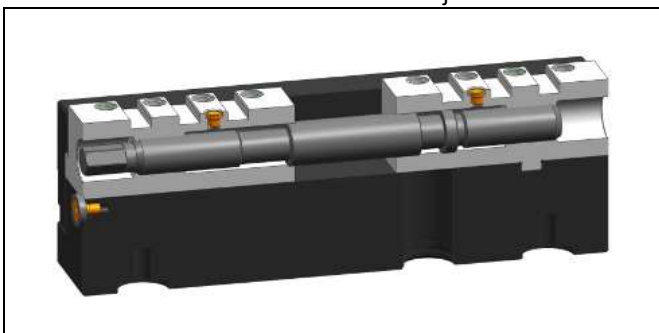

Fig. 1: Spindle drive

- Spindle drive with right/left thread.
- 1 slide fixed by feather key
- Clamping force build-up using torque wrench
- The clamping force develops proportionally to the torque.

### 7.2 Types of installation

#### **WARNING**

#### Risk of injuries due to improper product fixing!

If the product is fixed improperly, it may loosen from the machine bench or be damaged during clamping or processing.

- Install the product as instructed in the present Operation Manual.
- Ensure that the installation surface of the product base and the machine bench are clean before installation.
- The installation surface of the product base must be even and have a minimum overlap of 75 % on the machine bench.
- Install the product in accordance with the torque specified in the Operation Manual.
- Fix the product so that it may not be displaced by the processing forces.

#### Types of installation

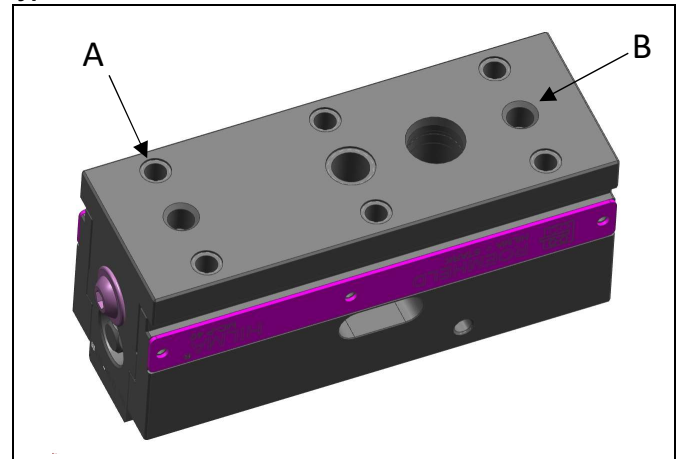

Fig. 2: Types of installation

A Tapped bore	B Dowel hole
---------------	--------------

Fastening on the machine table:

1. Unevenness and chips between the contact surface and the base surface shall be removed.
2. Alignment
  - with a load cell,
  - with dowel holes in the base.
3. Fixing
  - with bolts,
  - with clamping claws.

Special fixing kits may be ordered for each series.

## 8 Start-up

### **NOTE**

#### Lubrication before start-up

The elements are delivered with a minimum lubrication.

The sliding surfaces have to be lubricated lightly with track oil, ISO VG 220, before start-up!

- Check tight seat (check tightening torques of fixing screws).

**NOTE**
**Product operation on grinding machines**

When the product is used on grinding machines, the product will be more heavily contaminated.

- Clean product from contamination regularly.

**WARNING**
**Risk of injuries or damage to property by collision with system components!**

In the range of motion of the system components, persons may be injured by collision with system components, or damage to property may be caused by collision with other system components.

- Check the range of motion of the system components before start-up.

## 9 Operation

**WARNING**
**Vibration will loosen the product fixture!**

Vibration affects the workpiece fixture and results in an improperly fixed workpiece. An improperly fixed workpiece may be catapulted off the product during processing and result in personal injuries or damage to property.

- Exclude vibration on the product if possible.

**Risk of burns caused by hot workpieces!**

Hot workpieces may cause burns on parts of the body.

- Wear heat-resistant protective clothing.

**Bruises, burns and bone fractures caused by dropping workpieces!**

Workpieces may cause injuries when dropping.

- Wear safety shoes with safety level 1 (S1) as a minimum requirement.

**Risk of injuries by improperly mounted crank handle and/or torque wrench!**

An improperly mounted crank handle or torque wrench may slip off during operation and cause injuries to the operator.

- Check crank handle and/or torque wrench for proper seat.

**Risk of injuries due to limited range of motion of the crank handle and/or the torque wrench!**

When using the crank handle or the torque wrench, extremities may be squeezed between the crank handle and/or the torque wrench and objects in the range of motion.

- The range of the crank handle's and/or torque wrench's motion must be freely accessible.

**Risk of injuries during workpiece clamping!**

The workpiece properties may induce personal injuries during clamping if the workpiece is not clamped properly.

- Remove contamination on the clamping surfaces before clamping.
- Observe material properties of the workpiece during clamping.
- Observe workpiece shape during clamping.
- Observe workpiece clamping surface during clamping.
- Observe workpiece inertia during clamping.

**CAUTION**
**Risk of injuries by crushing of extremities during clamping**

The product is to be used in a manner so that the operator's own or other persons' extremities may not be squeezed during clamping.

- Keep your own or other persons' extremities off the clamping area during clamping.

**Risk of injuries due to exertion during clamping and unclamping of the product**

When unclamping the product, high forces have to be overcome initially. Persons may slip off the product during unclamping and be injured.

- Be careful and proceed slowly when unclamping the product.

**NOTE**
**Processing with mounted crank handle and/or torque wrench is impermissible**

Processing with mounted crank handle and/or torque wrench on the product is not permissible.

- Remove the crank handle and/or torque wrench from the product before processing a workpiece..

### 9.1 Setting the clamping range

1. Position torque wrench on external hex.
2. Adjust the clamping range using the torque wrench so that the workpiece may be inserted.
3. Position the workpiece between the jaws (not included in the scope of supplies).
4. Adjust the clamping range using the torque wrench so that the jaws are in contact with the workpiece.
5. Check clamping range overlap (min. 2 mm).

### 9.2 Clamping and releasing

**WARNING**
**Risk of injuries due to flexible or insufficiently clamped workpieces!**

Flexible or insufficiently clamped workpieces may be catapulted off the machine or drop and cause personal injuries during processing.

- Only use the product for clamping rigid workpieces.
- Sufficiently clamp the workpiece before processing.

**Risk of injuries due to insufficient clamping force or insufficient workpiece clamping!**

Insufficient clamping force or insufficiently clamped workpieces may be catapulted off the machine or drop and cause personal injuries during processing.

- Have the product checked for its operational reliability by a qualified expert after extended downtimes, repair work, and at regular intervals.
- Have the product checked for its defined clamping force by a qualified expert.
- Have the product checked for visual damage or wear by a qualified expert.
- Check whether the product is fixed properly before product start-up.
- Check whether the workpiece is clamped properly before product start-up.

1. The clamping force is increased by rotating the spindle clockwise by means of a torque wrench.
2. Observe maximum values (see Section 12 "Technical data").
3. The clamping force is reduced by rotating the spindle counter-clockwise by means of a torque wrench.

## 10 Maintenance

### **WARNING**

#### Burns on hot surfaces!

- In operation, surface temperatures of over 70°C may develop on the product.
- Maintenance and repair work should only be performed in a cooled down condition and/or with protective gloves.

#### Risk of injuries by breaking product parts!

During operation, product parts may break, and this may cause personal injuries.

- Observe maintenance intervals for all parts pursuant to this Operation Manual.

### 10.1 Maintenance schedule

Maintenance work	Interval	Performance
Cleaning	As required	Operator
Regular checks	Daily	Operator
Regular lubrication	At least once a month, after 500 clamping cycles at the latest!	Operator  <b>Caution!</b> If this lubrication is omitted, the tensioner may fail!
Repair	As required	Expert staff

### 10.2 Cleaning

#### **CAUTION**

#### Damage to moving components!

Avoid damage to movable components (spindle and slide).

#### Aggressive cleaning agents

The product must not be cleaned:

- with corrosive or caustic substances or
- organic solvents such as halogenated or aromatic hydrocarbons and ketones (cellulose thinner, acetone, etc.).

The element has to be cleaned at regular intervals. In this regard, the spindle drive area and the housing have to be cleaned from chippings and liquids in particular.

In case of heavy contamination, cleaning intervals have to be shortened.

### 10.3 Regular checks

1. Check clamping force regularly using a force measuring gauge.
2. Observe maintenance intervals.

### 10.4 Regular spindle lubrication

Fig. 3: Spindle lubrication via lubricating nipples (A)

The following maintenance and care work is to be performed as required, however once a month, each:

1. Lubricate spindle thread with track oil.
2. Lubricate spindle chamber with track oil.
3. Lubricate guide runways with track oil.

### 10.5 Service / maintenance service

1. In Germany  
Maintenance by manufacturer  
Please send the clamping system free of transportation charges.

Stark Spannsysteme GmbH  
Römergrund 14  
6830 Rankweil, Austria  
Service-Telefon: +43 5522 / 37400-0  
E-Mail: service@stark-inc.com

Maintenance at customer workshop:  
Please call maintenance service

Service-Telefon: +49 6405 / 89-400  
E-Mail: service@roemheld.de

2. Internationally  
Please contact the HILMA-RÖMHELD general importer or your local dealer.

## 11 Troubleshooting

Error	Cause	Remedy
Slide has backlash	Guide rail is worn	Replace vice
No clamping pressure build-up	Clamping range set incorrectly.	See "Setting the clamping range" Section.

## 12 Technical data

### Parameters

Typ 4581-0101	
Jaw width [mm]	40
Max. clamping force [kN]	7,5
Torque [Nm]	23
Clamping stroke [mm]	20
Base length [mm]	110
Mass [kg]	1,5

Clamping force progression MC-P 40

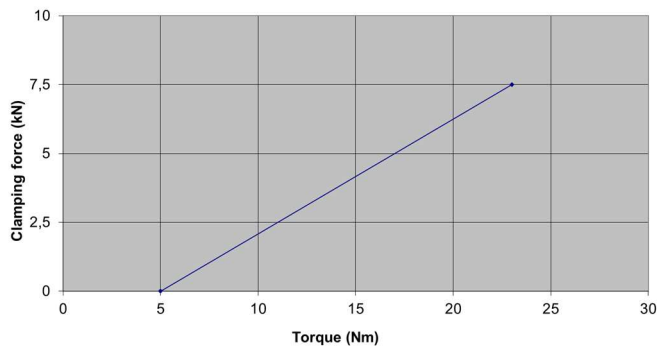

### NOTE

#### Other data

- For more technical data, please refer to the catalogue sheet.

### Proposal, tightening torques for screws of strength classes 8.8; 10.9; 12.9

### NOTE

- The values indicated are to be considered as approximate values and to be interpreted by the user in each individual case!  
See note!

Threads	Tightening torques (MA) [Nm]		
	8.8	10.9	12.9
M6	10	15	18
M8	25	36	45
M10	49	72	84
M12	85	125	145
M14	135	200	235
M16	210	310	365
M20	425	610	710

**Note:** Applicable to workpieces and shaft screws of steel with metric threads and head bearing dimensions as DIN 912, 931, 933, 934 / ISO 4762, 4014, 4017, 4032

The tightening torque (MA) values in the table take account of: Steel/steel design, friction value  $\mu_{ges} = 0.14$  - not lubricated; utilization of minimum yield strength = 90%

### 12.1 Storage

#### CAUTION

#### Component storage!

- The product must not be exposed to direct sunlight, since UV light may cause serious damage to the gaskets.
- Storage not in compliance with the specified storage conditions is impermissible.
- Improper storage may result in the embrittlement of gaskets and in the resinification of the corrosion protection oil and/or in corrosion on the element.

ROEMHELD products are tested with mineral oil by default. Products are treated with corrosion inhibitor on the outside. The oil film remaining after the test ensures inside corrosion protection for six months if the product is stored in dry and evenly tempered rooms.

For extended storage periods, the product must be filled with a non-resinating corrosion inhibitor, and the outside surfaces have to be treated.

### 12.2 Accessories

#### NOTE

#### Accessories

- See catalogue sheet.

## 13 Disposal



#### Hazardous to the environment

In order to avoid potential environmental damage, the individual components have to be disposed of by approved expert companies.

All materials have to be disposed of in compliance with the applicable codes and regulations as well as environment protection regulations.

Particular importance is to be attached to the disposal of components containing residues of pressure liquids. The notes regarding disposal in the safety data sheet have to be observed.

As regards the disposal of electrical and electronic components (e.g. position sensors, proximity switches, etc.), the country-specific statutory requirements and regulations have to be complied with.

## 14 Installation statement

### Manufacturer

Hilma-Römheld GmbH  
Auf der Landeskrone 2  
57234 Wilnsdorf-Wilden Germany  
Tel.: +49 (0) 2739 / 4037-0  
E-Mail: [info@hilma.de](mailto:info@hilma.de)  
[www.roemheld.de](http://www.roemheld.de)

Products of catalogue sheet WS 5.4501. These cover the types and/or order numbers:

- 9.4581.0101

They have been designed and manufactured pursuant to directive **2006/42/EG** (EG-MSRL) as revised as well as the applicable technical codes.

Pursuant to EG-MSRL and EN 4412, these products are components not ready for use and exclusively intended for installation into a machine, device or system.

Pursuant to the pressure equipment directive, the products are not classified as pressure vessels, but as hydraulic adjustment device, since the pressure is not the essential factor for the design, but strength, inherent stability and stability against static and dynamic operation loads.

The products may not be operated until it has been determined that the incomplete machine and/or the machine in which the product is to be installed complies with the machinery directive (2006/42/EG).

The manufacturer agrees to submit the product-specific documents to government agencies upon request.  
The technical documentation for the products pursuant to Annex VII Part B has been prepared.

### 14.1 List of applicable standards

**Product Safety Act [ProdSG];** November 2011

**DIN EN ISO 12100**, 2011-03, Safety of machinery; Basic terminology, general principles for design (supersedes Parts 1 and 2)

**DIN EN ISO 13857; 2008-06**, Safety of machinery - Safety distances to prevent hazard zones being reached by upper and lower limbs. (supersedes: DIN EN 294)

**DIN EN 349**, 2008-09, Safety of machinery; minimum distances to avoid crushing of parts of the human body

**DIN EN 81714-2**, 2007-08, Design of graphic symbols for use in technical product documentation

**DIN EN 82079; 2010-10**, Preparation of Instructions for Use - Structuring, Content and Presentation – Part 1

Technical documentation officer:  
Thomas Willingshofer, Tel.: +49 (0) 2739 / 4037-193

**Hilma-Römheld GmbH**

**Nico Hanke**

**Managing director**



Wilnsdorf-Wilden, October 17, 2022