

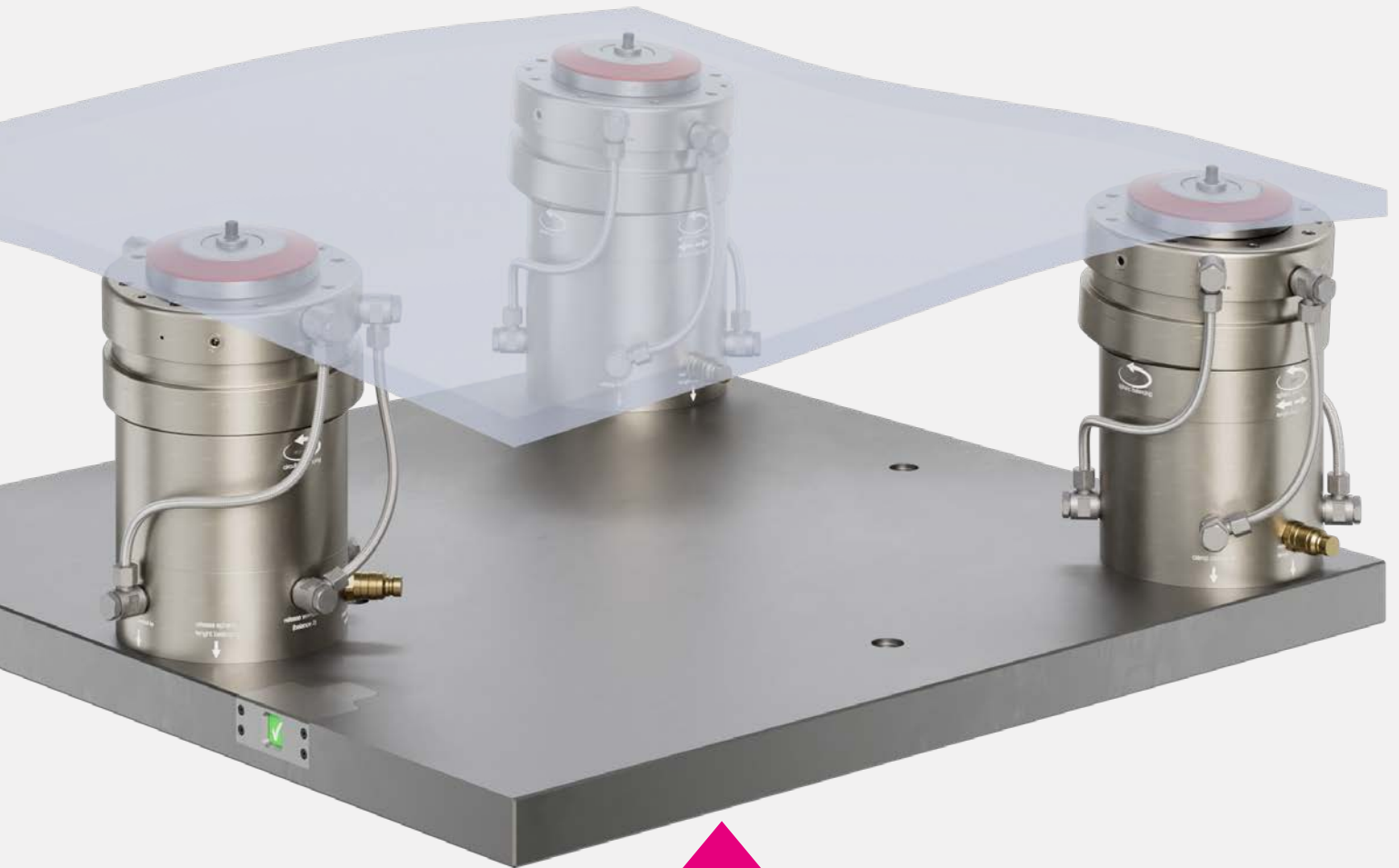

ROEMHELD
HILMA ■ STARK



STARK.spheric

Clamping concept for large workpieces
flexible, tension-free, hydraulic



ROEMHELD
HILMA ■ STARK



STARK
INNOVATIVE
PROFICIENT
INDIVIDUAL
RELIABLE

The high-tech company STARK Spannsysteme, founded in 1977, is regarded as a pioneer in the development and manufacture of zero point clamping systems, being the first company on the market to specialise exclusively in this technology for decades.

High quality and precision distinguish what is possibly the broadest product range available on the market in the field of highly productive work-piece clamping.

Production is more efficient and flexible with STARK components, products and systems.



AUTOMOTIVE



AVIATION



MACHINE AND TOOL
CONSTRUCTION



MEDICINE

FOCUS ON INDUSTRIES & MARKETS.

Every customer has specific requirements. Our established and extensive industry expertise allows us to offer you the best solutions, services and products for sustainable and efficient use in your market.

STARK.spheric

- Fast:** tension-free clamping between operations
- Flexible:** pendulum compensation up to $\pm 5^\circ$
- Compensating:** length compensation up to $\pm 1.5\text{ mm}$
- Raised design:** optimum accessibility
- Stable:** best suited for large devices



STARK.spheric



STARK.basic



STARK.connect

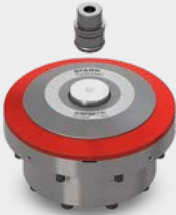

STARK.hydratec



STARK.airtec

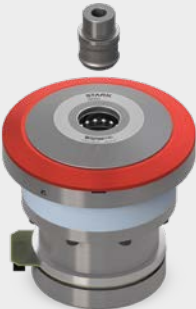

STARK.etc



STARK.sweeper



STARK.easyclick



STARK.classic



STARK.plaintec



STARK.metec

STARK
Spannsysteme

More productivity through:

- maximum flexibility in production
- highest process reliability
- reduced manufacturing costs due to set-up time optimisation



STARK.spheric table of contents

INFORMATION

STARK.spheric	6
Design	7
Equaliser mechanism	8
Control & fixation	9

SURFACE-MOUNTED ELEMENT

STARK.spheric with connections at the side	10
STARK.spheric with media duct	11

APPLICATIONS

Example with 2x clamping	12
Example with 3x clamping example	13
Aviation	14

FIXATION

STARK.balance.2 retractable nipple with zero point	15
STARK.classic.2 retractable nipple with zero point	15

ACCESSORIES

RECORD pressure booster	16
COMFORT pressure booster	16
Hydraulic hose with couplings	17
Pedal controller	17
Air-hydraulic clamping pump	17
Specification dimension tester	18
Mechanical insertion force tester	18
List of order numbers	19

PRECISION IN ITS MOST FLEXIBLE FORM

STARK.spheric

In a world where every micrometer counts and manufacturing processes are becoming increasingly complex, STARK.spheric sets new standards in intelligent clamping. The system combines uncompromising zero point accuracy with an innovative equaliser mechanism – for absolute precision.

Challenges such as component distortion, residual stresses, and thermal expansion arise particularly with large-volume workpieces with high machining rates – such as in aviation or in mechanical and plant engineering. Accessibility is also an important issue when dealing with complex geometries.

STARK.spheric solves these challenges through a combination of active feed, degree of freedom-controlled pendulum and length compensation, and precise zero-point clamping – even with complex geometries and changing clamping conditions.



Clamping without deformation

- ▶ No stress on the workpiece
- ▶ Better processing results
- ▶ Precise repeat accuracy



Stability & Flexibility

- ▶ Stable for processing
- ▶ Flexible for changing construction geometries
- ▶ Highest process reliability



Accessibility

- ▶ Height gain for better accessibility in clamping situations
- ▶ Trouble-free processing procedure

Areas of application

Industry	Application	Challenge/requirement
Aviation	Structural components (e.g., frames, fuselage shells, wing spars) made of aluminium or titanium	Very high machining volumes, thin-walled geometries, high demands on dimensional accuracy and surface quality
Space industry	Support frames, antenna structures, panels for satellites or rocket stages	Lightweight construction with maximum precision, expensive materials (e.g. titanium, Inconel), vibration-free clamping required
Machine & plant construction	Machine beds, clamping surfaces, large support structures	Often cast or welded assemblies with internal stresses; even force distribution during clamping is crucial to prevent distortion
Energy & turbine construction	Housing components for steam turbines, generator supports, large compressor components	Solid parts with tight tolerances and complex machining, difficult handling, high demands on the stability of the clamping fixture
Shipbuilding & offshore	Sections for ship hulls, bracing, large-scale components made of steel or aluminium	Often severely warped, irregular geometries, flexibly adaptable clamping solutions
Railed vehicle construction	Car bodies, chassis frames, supporting structures made of aluminium profiles	Long and vulnerable structures with a high proportion of machining, clamping devices must be continuous and stable over their entire length

Design

Equaliser mechanism



Pendulum equalisation
▶ more on page 8



Length equalisation
▶ more on page 8

Connections

- Clamping monitoring input
- Release STARK.spheric
- Release STARK.balance.2
- Clamping monitoring output

Media duct

with connections on the side



— Versions/designs

— Standard



Equaliser mechanism

STARK.spheric takes the equaliser options of a zero point clamping system to a whole new level. This system enables angle equalisation while ensuring a highly accurate zero point, thereby guaranteeing process reliability.

- + Equalisation of component distortion through high machining rates
- + Equalisation of angular errors

Zero point and axis alignment are retained and are always known. In total, up to ± 1.5 mm can be equalised. During pendulum motion, the height in Z remains constant.

Equaliser versions:

- ▶ with zero point and pendulum compensation in one/all directions
- ▶ with length compensation in one direction and pendulum compensation in all directions
- ▶ without centring, with pendulum compensation in all directions

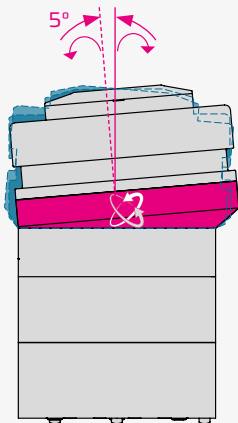

PENDULUM COMPENSATION

- Equalisation of angles up to $\pm 5^\circ$ in one direction
- Equalisation of angles up to $\pm 5^\circ$ in all directions

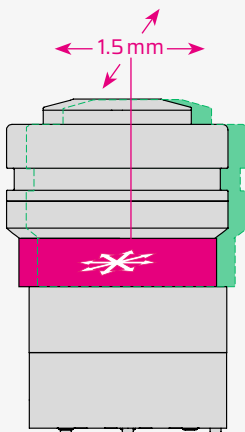

LENGTH COMPENSATION

- Displacement in one direction ± 1.5 mm with equaliser (AG)
- Displacement in all directions ± 1.5 mm without centring (OZ)

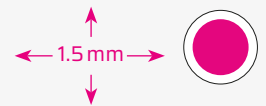
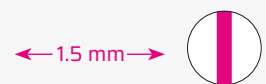

Control & fixation

STARK.spheric is connected to the base plate via a clamping element integrated into the lower part. This allows the clamping position to be easily and quickly adjusted to different workpieces.

In addition to the hydraulic line for positioning, STARK.spheric requires another hydraulic line to activate/enable the compensation functions and for the actual workpiece clamping. In addition, it is possible to evaluate pneumatic clamping monitoring to ensure reliable workpiece clamping.

There are two options available for supplying the necessary media:

- Via integrated media transfers in STARK.spheric and counterparts embedded in the base plate and guided lines
- Via connections at the side directly on STARK.spheric

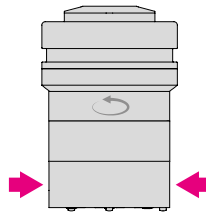

Media transfer via connections at the side

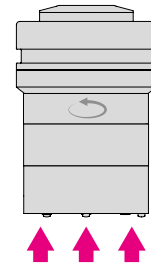

Media transfer via integrated media ducts

INFO

Optical clamping control

STARK.spheric has an integrated clamping monitoring function. Clamping monitoring is particularly useful and recommended for safety reasons in applications where visibility of the clamping point is restricted, for example when it is obscured by the workpiece.

The clamping control signal can be evaluated directly in the base plate and displayed visually there. For this purpose, the optical clamping control is activated accordingly via the clamping and release signals.



SURFACE-MOUNTED ELEMENT

STARK.spheric with connections at the side



- 1x surface-mounted element Ø202 x 300 mm
- 1x STARK.balance.2 (S801-207)
- 1x STARK.classic.NG.2 (S804-538)

Characteristics

STARK.spheric surface-mounted element

- 5x media transfer (at the side)
- Connection at the side for STARK.classic.NG.2
- Spheric release pressure: min. 60 bar, max. 80 bar
- Total weight: approx. 28 kg
- Material: aluminium
- Data sheet: D200
- Operating manual: WM-020-456

Characteristics

STARK.balance.2

- Hydraulic single acting
- Insertion force: 20 kN
- Retention force: 38 kN
- Release pressure: min. 60 bar, max. 80 bar
- Operating temperature: +10 up to +80 °C
- Material: tool steel, NBR
- Operating manual: WM-020-369

Characteristics

STARK.classic.NG.2

- Hydraulic single acting
- Insertion force: 22 kN
- Retention force: 38 kN
- Release pressure: min. 40 bar, max. 80 bar
- Operating temperature: +10 up to +80 °C
- Material: tool steel, NBR
- Operating manual: WM-020-332

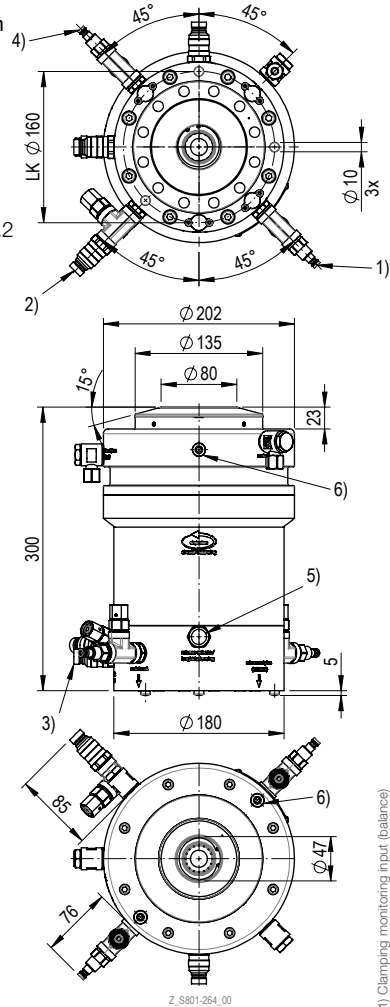

- 1) Clamping monitoring input (balance)
- 2) STARK.balance.2 release connection
- 3) STARK.classic.NG.2 release connection
- 4) Clamping monitoring output (balance)
- 5) STARK.spheric release connection
- 6) 4x M12 transport threads (2x 180° each)

Z_S801-264_00

Order number	Article designation	Compensation function	Description
S801-264	SA Z2 H 200 D135 EH SP NP R1		Zero point element for 2x clamping Pendulum compensation function ±5° in one axis
S801-265	SA Z2 H 200 D135 EH SP NP R2		Zero point element for 3x clamping Pendulum compensation function ±5° in all axes (directions)
S801-266	SA Z2 H 200 D135 EH SP AG		Element with length compensation function ±1.5 mm in one axis Pendulum compensation function ±5° in all directions
S801-267	SA Z2 H 200 D135 EH SP OZ		Element without centring Length compensation function ±1.5 mm in one axis Pendulum compensation function ±5° in all axes (directions)

STARK.spheric with media duct



- 1× surface-mounted element Ø202 x 300 mm
- 1× STARK.balance.2 (S801-207)
- 1× STARK.classic.NG.2 (S804-538)

Characteristics

STARK.spheric surface-mounted element

- 4× media transfer NW 4 (bottom side)
- Connection at the side for STARK.classic.NG.2
- Spheric release pressure: min. 60 bar, max. 80 bar
- Total weight: approx. 28 kg
- Material: aluminium
- Data sheet: D200
- Operating manual: WM-020-456

Characteristics

STARK.balance.2

- Hydraulic single acting
- Insertion force: 20 kN
- Retention force: 38 kN
- Release pressure: min. 60 bar, max. 80 bar
- Operating temperature: +10 up to +80 °C
- Material: tool steel, NBR
- Operating manual: WM-020-369

Characteristics

STARK.classic.NG.2

- Hydraulic single acting
- Insertion force: 22 kN
- Retention force: 38 kN
- Release pressure: min. 40 bar, max. 80 bar
- Operating temperature: +10 up to +80 °C
- Material: tool steel, NBR
- Operating manual: WM-020-332

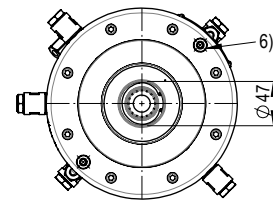
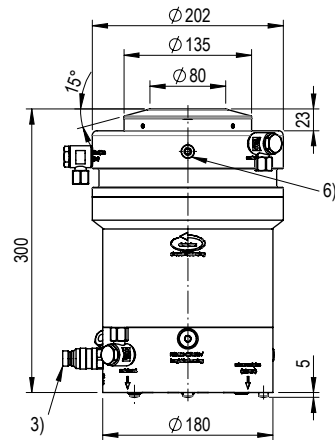
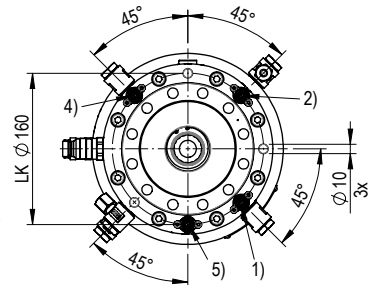

Z_S801-260_00

- 1) Clamping monitoring input (balance)
- 2) STARK.balance.2 release connection
- 3) STARK.classic.NG.2 release connection
- 4) Clamping monitoring output (balance)
- 5) STARK.spheric release connection
- 6) 4× M12 transport threads (2× 180° each)

Order number	Article designation	Compensation function	Description
S801-260	SA Z2 H 200 D135 EH SP NP R1 MD4		Zero point element for 2× clamping Pendulum compensation function ±5° in one axis
S801-261	SA Z2 H 200 D135 EH SP NP R2 MD4		Zero point element for 3× clamping Pendulum compensation function ±5° in all axes (directions)
S801-262	SA Z2 H 200 D135 EH SP AG MD4		Element with length compensation function ±1.5 mm in one axis Pendulum compensation function ±5° in all directions
S801-263	SA Z2 H 200 D135 EH SP OZ MD4		Element without centring Length compensation function ±1.5 mm in one axis Pendulum compensation function ±5° in all axes (directions)

APPLICATIONS

Application example - 2x clamping

The STARK.spheric can be used for clamping, for example, support structures with two clamping points. The zero point element allows angular errors of up to $\pm 5^\circ$ to be compensated for in the direction of the second clamping element only. This, in turn, can compensate for angles in all directions and also length compensation of $\pm 1.5\text{ mm}$ in the clamping direction. This ensures that the reference point can be clamped without tension and in a process-reliable manner despite deformation.

Clamping concept

- Carrier set-up with two STARK.spheric units
- Equalisation of distorted or curved surfaces for tension-free clamping of components
- Relieving tension in the component between two machining steps without losing the zero point by separately releasing the equalisation

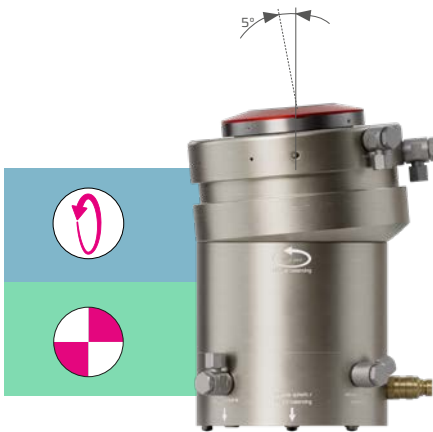

STARK.spheric
with zero point (S801-260)

- ▶ Pendulum compensation of $\pm 5^\circ$ in one direction without changing the zero point in the position.

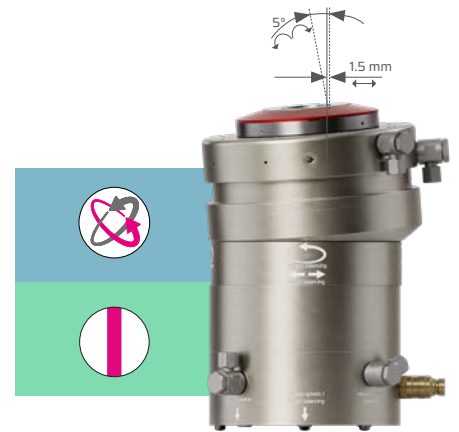

STARK.spheric
with equaliser (S801-262)

- ▶ Pendulum compensation of $\pm 5^\circ$ in all directions
- ▶ Length compensation of $\pm 1.5\text{ mm}$ in one direction

Legend

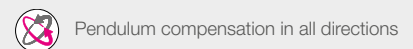
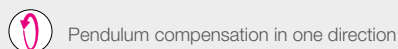

Application example - 3x clamping

In the example of a classic three-point support, the zero point element determines the absolute position, but can still compensate for an angular error of up to $\pm 5^\circ$ in all directions. The clamping element with compensation also compensates for angles of up to $\pm 5^\circ$ in all directions and additionally for a displacement in one direction of ± 1.5 mm. The STARK.spheric without centring allows for angular compensation and a displacement of ± 1.5 mm in all directions.

Clamping concept

- Set-up of flat components with three STARK.spheric units
- Relieving tension in the component between two machining steps without losing the zero point by separately releasing the equalisation



STARK.spheric
with zero point (S801-261)

- ▶ Pendulum compensation of $\pm 5^\circ$ in all directions, without changing the zero point in the position.

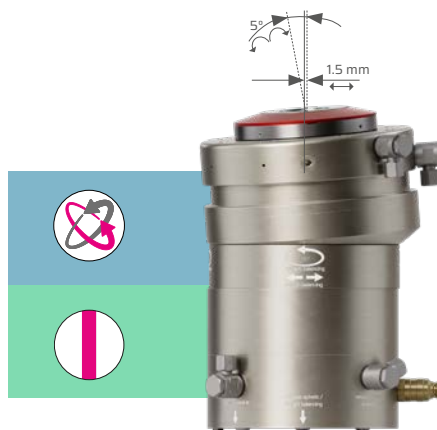

STARK.spheric
with equaliser (S801-262)

- ▶ Pendulum compensation of $\pm 5^\circ$ in all directions
- ▶ Length compensation of ± 1.5 mm in one direction



STARK.spheric
without centring (S801-263)

- ▶ Pendulum compensation of $\pm 5^\circ$ in all directions
- ▶ Length compensation of ± 1.5 mm in all directions

 Without length compensation – zero point

 Length compensation function in one direction

 Length compensation function in all directions

Application example - Aviation industry

Fast clamping without distortion between operations

- Up to 90 % machining volume
- High residual stresses
- + Defined relief between processing steps
- + Stable zero point despite equalisation

In the aviation industry, structural components must meet the highest standards of dimension-

al accuracy, surface quality and strength. The machining volume is extremely high, especially for large-format workpieces such as fuselage sections, wing components or frames – often up to 90 % of the material is removed in order to achieve a lightweight and stable structure.

This removal of material inevitably releases internal stresses. During machining, the clamping fixture stabilises the workpiece, but after release, these stresses can be released and cause distortion.

However, specialised clamping solutions are required to ensure dimensional accuracy and functional safety:



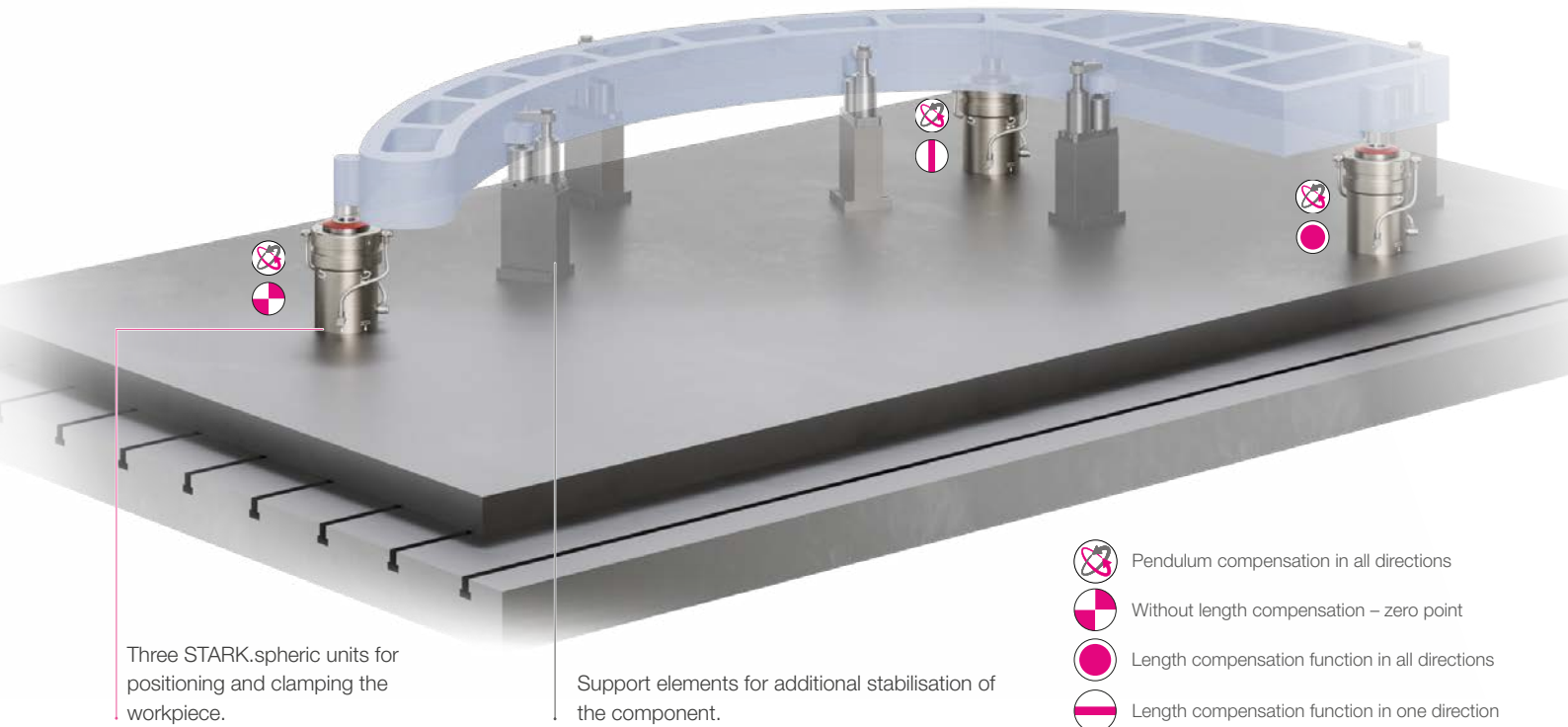

- Even force distribution
- High rigidity of the fixture
- Defined relief between processing steps
- Consideration of thermal and mechanical influences

This ensures that the workpiece remains precise, stable and functional even after machining.



Three STARK.spheric units for positioning and clamping the workpiece.

Support elements for additional stabilisation of the component.

-  Pendulum compensation in all directions
-  Without length compensation – zero point
-  Length compensation function in all directions
-  Length compensation function in one direction

Clamping process without distortion

1. Creation of the clamping concept

The reference planes must be defined depending on the workpiece and the intended machining strategy. These subsequently define the position of the zero point and the permissible degrees of freedom. Suitable mounting points must be determined in the workpiece into which the retractable nipples can be screwed. The rigidity and vibration behaviour of the workpiece must be taken into account. If necessary, additional flexible clamping elements or supports may be required at critical points. This also prevents bouncing during processing.

2. Clamping the workpiece

For the loading process, the STARK.spheric is completely released – both the clamping function and the compensation function. Once the workpiece has been positioned, the clamping process can begin. The compensation functions of the STARK.spheric are then locked. This prevents the workpiece from being accidentally distorted during the clamping process.

Optionally, the clamping monitoring can be queried to check that the workpiece is clamped correctly and securely.

3. Machining & residual stress

After clamping, machining of the workpiece can begin. Between individual machining steps, it may be necessary to release the residual stresses that have developed in the workpiece. To this end, the equaliser mechanism of the STARK.spheric is briefly released to allow for compensatory movements. After re-locking, machining can be continued.

RETRACTABLE NIPPLE FOR WORKPIECE CLAMPING

STARK.balance.2 retractable nipple with zero point



- Retractable nipple for STARK.balance direct clamping fast closing clamps
- Retractable nipple with zero point
 - with fit
 - Material: tool steel
 - Installation according to data sheet D029-2

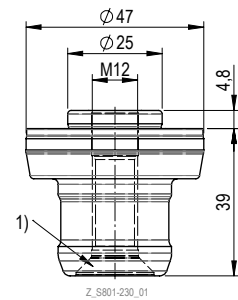

1) Countersink for M10 screw

Order number	Article designation	Thread (M)	Collar	Length	Weight
S801-230	EL Z2 NP 250 12 048	M12	4.8mm	39.0mm	0.3kg

STARK.balance.2 retractable nipple with zero point



- Retractable nipple for STARK.balance direct clamping fast closing clamps
- Retractable nipple with zero point
 - without fit
 - Material: tool steel

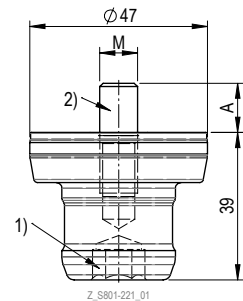

1) Width across flats SW 12

Order number	Article designation	Thread (M)	Tightening torque	Thread length (A)	Length	Weight
S801-221	EL Z2 NP 000 10 000 EG	M10	45 Nm	13mm	39.0mm	0.3kg
S801-222	EL Z2 NP 000 12 000 EG	M12	60 Nm	12mm	39.0mm	0.3kg
S801-223	EL Z2 NP 000 16 000 EG	M16	100 Nm	20mm	39.0mm	0.3kg
S801-224	EL Z2 NP 000 20 000 EG	M20	110 Nm	26mm	39.0mm	0.4 kg
S801-225	EL Z2 NP 000 24 000 EG	M24	123 Nm	33mm	39.0mm	0.4 kg
S801-226	ES Z2 NP 000 24 000 EG	M24x1	127 Nm	11.8mm	39.0mm	0.4 kg

RETRACTABLE NIPPLE FOR FIXING THE STARK.SPHERIC

STARK.classic.2 retractable nipple with zero point



- Retractable nipple suitable for fast closing clamps of the STARK.classic.2 and Twister versions.
- Retractable nipple with zero point
 - with fit
 - Material: tool steel
 - Installation according to data sheet D029-2

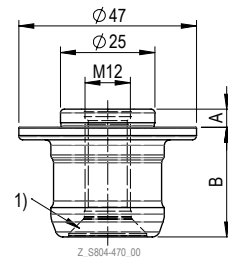

1) Countersink for M10 screw

Order number	Article designation	Area of application	Thread (M)	Collar (A)	Length (B)	Weight
S804-470	EB C2 NP 250 12 048	STARK.classic.NG.2	M12	4.8mm	29mm	0.17 kg

ACCESSORIES

RECORD pressure booster



The RECORD pressure booster converts air pressure into the required hydraulic system pressure for actuating the STARK.balance fast closing clamps.

- Version with 80bar
- Air pressure 6bar
- Weight 8.80kg
- Operating Manual WM-020-062

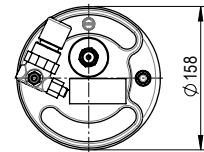
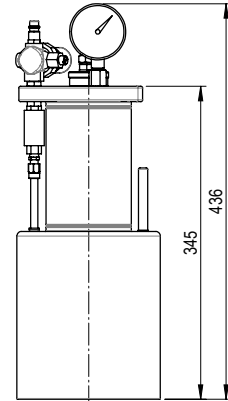

Z_S804-412_00

Order number	Article designation	Area of application/special feature	Oil volume
S804-412	"RECORD" pressure booster 80bar	Control of max. 5 STARK.balance.2 units up to max. 80bar (system pressure)	0.148l

COMFORT pressure booster



The pressure booster is used to release single-acting clamping systems. The booster converts compressed air into hydraulic pressure and is suitable for application areas of 80bar.

- Version with 80bar
- Air pressure 6bar
- Weight 27.30kg
- Operating Manual WM-020-334

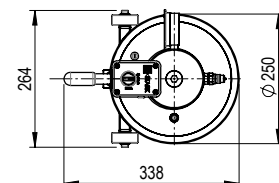
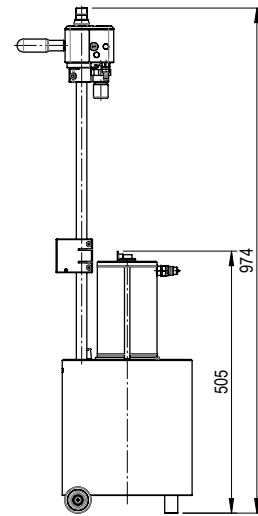

Z_S804-433_00

Order number	Article designation	Area of application/special feature	Oil volume
S804-433	"COMFORT" booster 80bar	Control of max. 20 STARK.balance.2 units up to max. 80bar (system pressure)	0.5l

Air-hydraulic clamping pump



Air-hydraulic pump (80 bar)
Actuation via integrated foot pedal
Oscillating air/oil pressure intensifier

- Inlet pressure 2.8 to 10 bar
- Pneumatic coupling plug
- Pressure gauge (0-100 bar)
- Oil volume 2.4l
- Hydraulic hose set S952-138 leakage oil-free
- Operating manual WM-020-410-xx

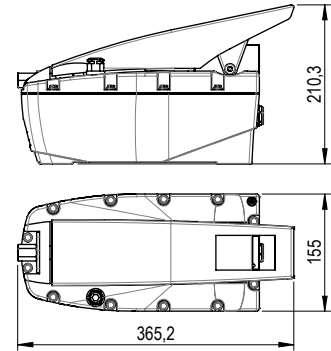

Z_S952-314_00

Order number	Article designation
S803-414	Air-hydraulic pump 80 bar with pressure gauge

Hydraulic hose with couplings



Hydraulic hose with hydraulic plug-in coupling on both sides. Used to connect between pressure booster and fast closing plate or surface-mounted element

- Max. pressure 300 bar

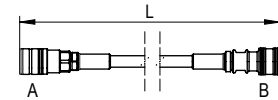

Z_S704-153_00

Order number	Article designation	Couplings A/B	Length L	Weight
S704-150	Hydraulic hose set	A/B: Standard (S952-044)	1.5 m	0.63 kg
S704-151	Hydraulic hose set	A: Leak-free (S952-177) / B: Standard (S952-044)	1.5 m	0.63 kg
S704-152	Hydraulic hose set	A/B: Standard (S952-044)	3.0 m	0.85 kg
S704-153	Hydraulic hose set	A: Leak-free (S952-177) / B: Standard (S952-044)	3.0 m	0.85 kg

Pedal controller

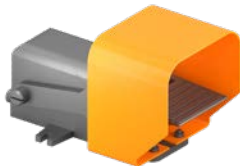

Pedal controller for controlling the pressure booster

- Control of the pressure booster via foot controller
- The pressure booster does not have to be located in the immediate vicinity
- Both hands are free for loading or for removing the workpieces to be processed
- Weight 1.5 kg

Order number	Article designation
S804-419	Pedal controller for pressure booster (incl. pneumatic hose and screw-in connections)

Specification dimension tester



S504-022

The specification dimension tester is used to check the specification dimension according to the operating manual of the respective element types.

The DH specification dimension tester is used to check the function of the DH position (third-hand function) and its setting

- Supplied in a plastic case
- Incl. calibration piece
- Operating Manual WM-020-349-xx-xx

Order number	Article designation
S504-022	Specification dimension tester for STARK.classic.NG.2
S504-029	Specification dimension tester for STARK.balance.2 (direct clamping)

Mechanical insertion force tester



S504-000

The insertion force tester is used to reliably check the insertion force of the STARK fast closing clamps.

The insertion force may change depending on actuation cycles and wear. As a result, the specified insertion force is no longer achieved and the machining forces are no longer fully absorbed by the zero point clamping system. As a preventive measure, STARK recommends regular inspection of the clamping elements (see operating manual).

Order number	Article designation	Weight
S504-002	Mechanical insertion force tester STARK.classic.2/NG.2	7.1 kg
S504-005	Mechanical insertion force tester STARK.balance.2 (direct clamping)	5.8kg
S504-000	Rental case: Mechanical insertion force tester STARK.balance.2/3	-

INFO

Mechanical insertion force tester



Supplied in a practical plastic case (L390 × W280 × H110)



Insertion force tester (1) with calibration certificate and operating manual in the plastic box, with support ring (2), adapter retractable nipple (3) and spacer (4)

STARK.spheric order number list

S504-000	18	S801-230	15
S504-002	18	S801-260	11
S504-005	18	S801-261	11
S504-022	18	S801-262	11
S504-029	18	S801-263	11
S704-150	17	S801-264	10
S704-151	17	S801-265	10
S704-152	17	S801-266	10
S704-153	17	S801-267	10
S801-221	15	S803-414	17
S801-222	15	S804-412	16
S801-223	15	S804-419	17
S801-224	15	S804-433	16
S801-225	15	S804-470	15
S801-226	15		

A COMPANY OF THE
ROEMHELD GROUP

STARK

Spannsysteme

The ROEMHELD Group consists of 5 companies at locations in Germany and Austria, each with different products and orientations. With numerous subsidiaries, sales partners and service companies on all continents and in more than 50 countries, rapid and intensive customer support is provided in the mechanical engineering, medical technology, automotive, aviation and agricultural industries.

As part of the ROEMHELD group of companies, STARK benefits from the security and experience of a family-run traditional company as well as from the worldwide sales and service network. At the same time, this background provides the independence to pursue dynamic and innovative goals for new market-driven developments and customer-specific solutions with which STARK maintains its leading technological position.



ROEMHELD
HILMA ■ STARK

STARK Spannsysteme

A company of the ROEMHELD Group

STARK Spannsysteme GmbH
Römergrund 14 | 6830 Rankweil
Austria

+43 5522 37 400 - 0
info@stark-roemheld.com

stark-roemheld.com