

Einbaubeispiel 1
 installation example 1

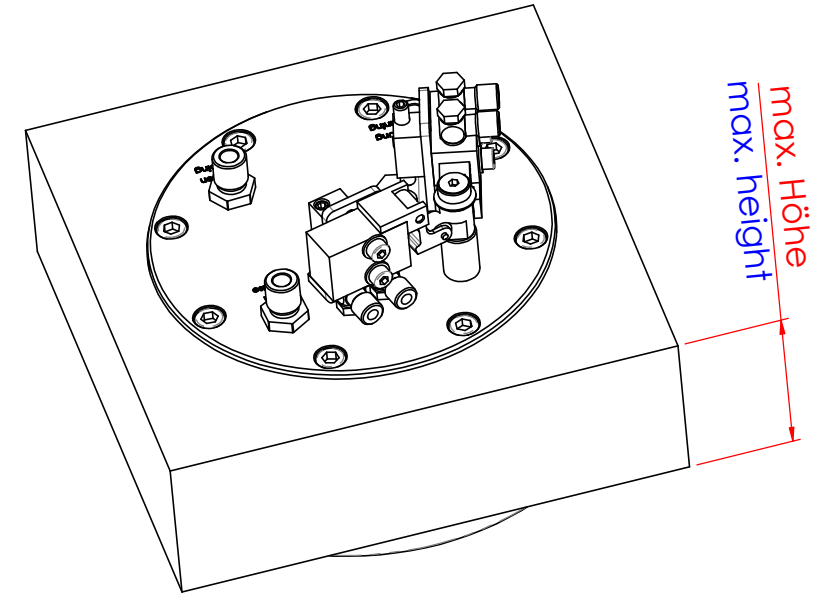

Einbaubeispiel 2
 installation example 2

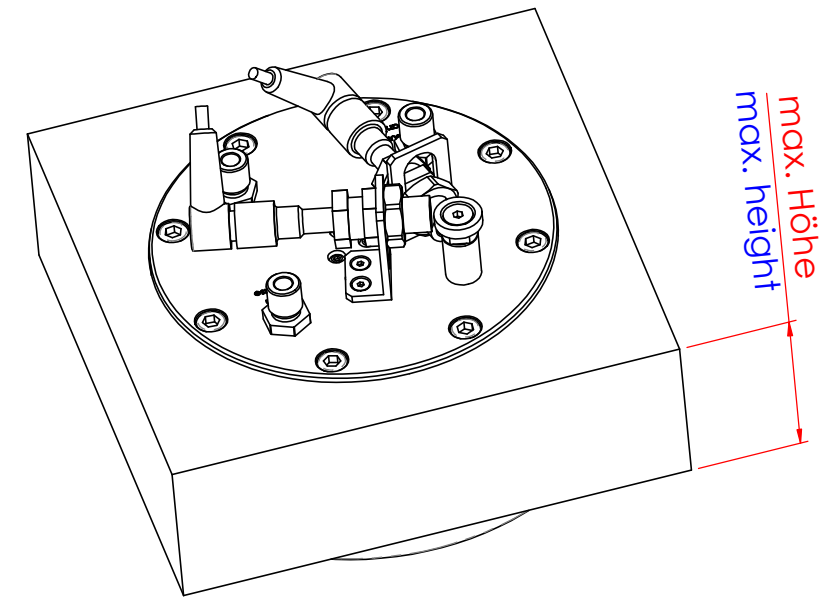

Ra0,8 (Ra0,4)

				Datum / date	Name:	Oberflächen- Wärme- Behandlung:	
				Gez.: 2017-11-16	lats		
				Gepr. 2021-07-30	japr		
				unbemaßte Toleranz / dimensions without tolerance: $\pm 0,1$		Bemerkung: Änderungen vorbehalten subject to change	
				Material / material:			
A	1323	2021-07-30	japr	Benennung / description			
Index	Änd.-Nr.	Datum	Name	Einbaumaße / assembly dimensions STARK.sweeper Modul / module pneumatisch / pneumatic			
ROEMHELD HILMA ■ STARK Stark Spannsysteme GmbH Römergrund 14 / A-6830 Rankweil Tel.: +43 (0) 55 22 / 37 400-0				Maßstab / scale M 1:1.4		Zeichnungsnr. / drawing no. D096	
				Blatt / page 1 / 1			