



ROEMHELD
HILMA ■ STARK

STARK.basic zero point clamping system

Translation of the original operating manual

WM-020-379-11-en BA STARK.basic



STARK.basic S / M / Y

Art. no.: 8000 001 - 8000 ...

Manufacturer:

STARK Spannsysteme GmbH
Römergrund 14
6830 Rankweil
Austria
+43 5522 37 400
info@stark-roemheld.com
www.stark-roemheld.com



1 Table of contents

1	Table of contents	2
2	Identification of the partly completed machinery	3
3	User instructions	3
3.1	Purpose of the document	3
3.2	Revision history	3
3.3	Presentation of safety instructions	3
4	Essential safety instructions	4
4.1	Intended use.....	4
4.2	Foreseeable misuse	4
4.3	When using rotating machine tools	4
4.4	Modifications or alterations	4
4.5	Spare and wear parts and auxiliary materials	5
4.6	Obligations of the operating company.....	5
4.7	Residual risks	5
4.7.1	Spring assembly	5
4.7.2	Malfunction in the pneumatics during operation.....	5
4.7.3	Excess pressure hazards	6
4.7.4	Danger due to incorrect assembly of the fast closing clamp.....	6
4.7.5	Danger during use when rotating	6
4.7.6	Influences on service life	6
5	Description of the fast clamping device.....	7
5.1	General.....	7
5.2	Assembly and installation.....	7
5.2.1	STARK.basic.S / M.....	7
5.2.2	STARK.basic.Y	8
5.3	Removing the fast closing clamp	9
6	Commissioning, handling and operation.....	9
6.1	Initial commissioning	9
6.2	Function check	9
6.3	Operation.....	9
6.4	STARK.basic with blow-out function and seat check.....	10
7	Maintenance and servicing.....	10
7.1	Function check	10
7.2	Spring assembly maintenance interval	10
7.3	Cleaning	11
7.4	General cleaning	11
7.5	Storage.....	11
7.6	Disposal/recycling	12
8	Technical data.....	12
9	Declaration of Incorporation.....	13



2 Identification of the partly completed machinery

Product: Fast closing clamp
 Function: Clamping and centring of workpiece pallets
 Optional: with blow-out and mount control
 Product group: STARK.basic.S / M / Y
 Article number S8000-001 bis S8000-XXX
 Trade name/
 General designation: corresponds to product group, see above

3 User instructions

3.1 Purpose of the document

This operating manual

- describes the function, operation and maintenance of the fast clamping device
- gives important instructions for safe and efficient use of the fast clamping device

3.2 Revision history

Date	Version	Revision	Name
20/04/2018	WM-020-379-10	Document creation	-
05/10/2023	WM-020-379-11	Technically revised	rohu

3.3 Presentation of safety instructions

Safety instructions are identified by a pictogram. The associated signal word describes the extent and severity of the impending hazard.

	DANGER	Immediate imminent risk to life and health of persons (serious injury or death). Be sure to follow these instructions and procedures!
	CAUTION	Potentially hazardous situation (minor injury or material damage) Be sure to follow these instructions and procedures!
	INFORMATION	Application tips and particularly useful information.
	INSTRUCTION	Obligation for special conduct or an activity for the safe handling of the machine.

4 Essential safety instructions

4.1 Intended use



The fast closing clamp is used for clamping pallets with mounting devices for workpieces.

The workpieces are intended for processing, transporting and measuring.

The intended use also presupposes:

- compliance with all the instructions in the operating manual
- observance of the inspection and maintenance intervals
- use of only OEM parts.

4.2 Foreseeable misuse



Any other use than that described in chapter

“4.1 Intended use“ or any use going beyond this is considered a misuse and is not permitted!

Risks may occur if the product is not used as intended. Improper uses include e.g.:

- exceeding the technical values specified for normal operation
- application for hoist operation and load transportation

The operating company bears sole responsibility for any injury or damage resulting from such improper use. The manufacturer assumes no liability.

4.3 When using rotating machine tools



For rotating applications, the fast closing clamp may only be operated if it is ensured that it is securely clamped. It must also be ensured that the permissible forces acting on the fast closing clamp are not exceeded according to the technical data.

Specialists must be consulted to calculate and design the fast clamping clamps for rotating applications. STARK Spannsysteme GmbH provides this service.

4.4 Modifications or alterations



Unauthorised modifications or alterations of the fast clamping device will void any liability and warranty on the part of the manufacturer!

Therefore do not make any modifications or alterations to the fast closing clamp and retractable nipple without consultation with and the written approval from the manufacturer.

4.5 Spare and wear parts and auxiliary materials



Only retractable nipples from STARK Spannsysteme GmbH may be used on the remote station and must be installed according to the appropriate data sheet of STARK Spannsysteme GmbH.

The use of spare and wear parts from third-party manufacturers can result in risks. Use only OEM parts or parts approved by the manufacturer. STARK Spannsysteme GmbH accepts no liability for damage resulting from the use of spare and wear parts or auxiliary materials not approved by STARK Spannsysteme GmbH.

4.6 Obligations of the operating company



The operating company is obliged to allow only persons to work on the fast clamping device who

- are familiar with the fundamental occupational health and safety and accident prevention regulations
- have been instructed in the use of the fast clamping device and have read and understood this operating manual.

The requirements of EC Directive 2007/30/EC on the use of work equipment must be observed.

4.7 Residual risks



Attention must be paid to the existence of mechanical and pneumatic residual energies at the fast clamping device and the pressure in the cylinders and valves after switching off the fast clamping device!

4.7.1 Spring assembly



Improper disassembly of the fast closing clamp can result in material damage or even injuries due to the internal, pre-tensioned spring assembly. Assembly work may only be carried out by STARK Spannsysteme GmbH.

4.7.2 Malfunction in the pneumatics during operation



Malfunctions in the pneumatics may cause an unintentional pressure increase in the release line and subsequently release the fast closing clamp. Particularly in rotating applications, this can result in a significant hazardous situation.

Possible measures to prevent accidental release:

- Mechanical disconnection of the release pressure line (decouple). This means that a pressure increase is no longer possible during operation.
- Decouple the safety valves from the machine pneumatics. This means that a pressure increase is no longer possible during operation.
- With integrated pressure monitoring in the release circuit of the fast closing clamp, the machine can be stopped in the event of an unintentional pressure increase.



4.7.3 Excess pressure hazards



Lines or hoses bursting due to excessive pressures can endanger persons and the environment.

Measure:

- Observe the specified pressure limits.

4.7.4 Danger due to incorrect assembly of the fast closing clamp



Incorrect tightening of the fixing screws or insufficient strength of the screws can cause the pallet to come loose.

Measure:

The mounting instructions for arrangement, strength class and tightening torque must be observed.

4.7.5 Danger during use when rotating



Excessive rotational speed, excessive weight or unbalance can lead to failure of the fast closing clamp. As a result, the pallet could be slung away.

Measure:

It is essential to observe the manufacturer's specifications and regulations regarding maximum values!

4.7.6 Influences on service life

Negative influences include:

- Insufficient filtering of the compressed air: a filter fineness of $<15\ \mu\text{m}$ must be guaranteed.
- External mechanical damage to functional components.
- Exceeding the specified forces or unintended load conditions.
- Overloading due to sudden pressure peaks.
- Heavy contamination of the functional parts (e.g. chips, casting or grinding dust, etc.)
- Aggressive media or environmental influences, e.g. coolants or lubricants, cleaning agents, UV radiation. This attacks seals and wipers.
- Incorrect loading position
- Damage due to excessive loading and unloading speed.
- Staying too long in the release position leads to unnecessary loads on the seals and springs.

5 Description of the fast clamping device

5.1 General

The fast closing clamp is the connection between the machine and the clamping device. There are corresponding retractable nipples on the clamping device, which are used for quick set-up.

While one pallet is being processed, the other can be set up.

5.2 Assembly and installation

5.2.1 STARK.basic.S / M

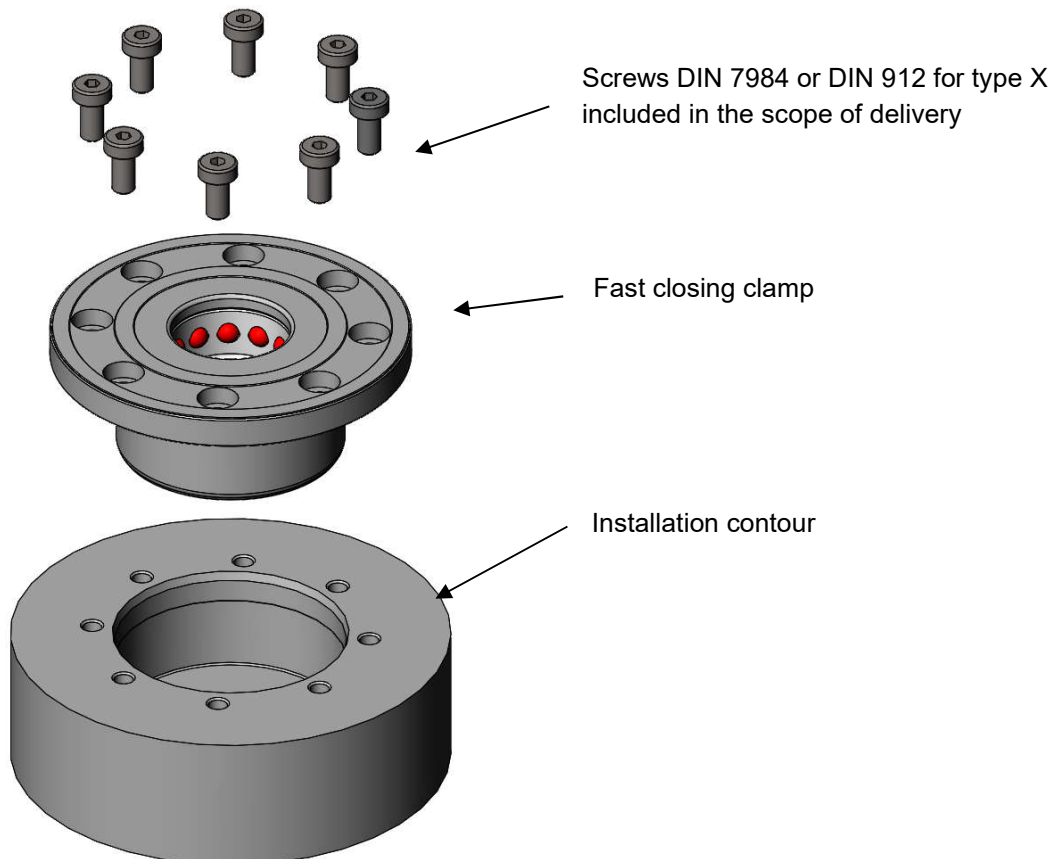

1. Check the installation contour for the STARK.basic for dimensional accuracy and surface quality. Important: The transition from the insertion chamfer to the centring bore must be burr-free, otherwise the O-ring may be damaged (leakage and failure of the fast closing clamp). All parts must be clean, this also applies to all supply lines. (deep-vores, pipes, hoses, etc.).



Important: Dirt and aggressive media can lead to malfunctions or failure of the fast closing clamp.

2. Grease the centring bore and O-ring well and push the fast closing clamp into the bore until the O-ring is in the locating and centring bore. Pay attention to the position of the screw countersinks and threaded bores. For STARK.basic with equaliser, also pay attention to the desired direction of equalisation.
3. The centring collar of the fast closing clamp is oversized compared to the centring bore of the installation contour. In order to insert evenly and without damage into the fit, screw the 2 screws into opposite countersinks and threaded bores until the screw heads in the countersinks are in contact without force (do not tighten yet). Tighten the two screws alternately in several steps and thus pull the fast closing clamp as straight as possible into the bore up to the flat support. Make sure that the fast closing clamp is not screwed tight on one side. Screw in the remaining screws and tighten them all to the appropriate tightening torque (observe the instruction leaflet).

i Important: Apply pressure to the fast closing plate only when screwed on. Check the retraction of all balls for each STARK.basic. The STARK.basic clamping systems can only function properly if the retractable nipple can be pushed into and removed from the locating bore without force. If the retractable nipple on one or more STARK.basic clamping system(s) cannot be pushed into and/or removed from the locating bore without force, the STARK.basic clamping system(s) concerned must be removed and checked in accordance with "5.3 Removing the fast closing clamp" points 1 - 3. Repeat points 2 - 3 of the "5.2.1 STARK.basic.S / M".

i You can find all installation data sheets for the STARK.basic clamping systems on our website. <https://www.stark-roemheld.com/nullpunktspannsysteme/stark-basic/>

Training

STARK Spannsysteme GmbH offers training courses to train your operating and service personnel. Training courses will take place at your premises or at STARK Spannsysteme GmbH. Please contact us for more information. We will be happy to advise you.

5.2.2 STARK.basic.Y

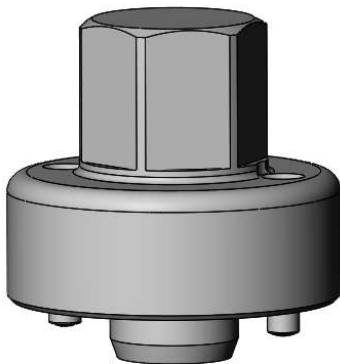

The same instructions apply as described under 5.2.1, but the STARK.basic Y is screwed into the plate via a central external thread. The mounting key, available under order no. S8000-899, is recommended for this purpose.

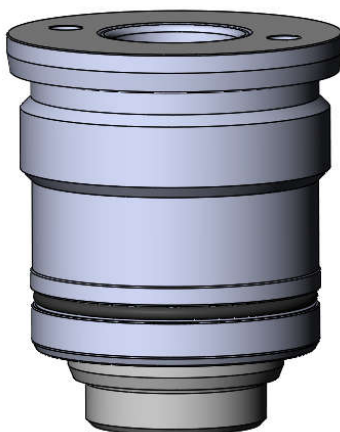



5.3 Removing the fast closing clamp

1. The system must be completely depressurised before disassembly is started. Disconnect the energy supply to the pressure generator, prevent unintentional commissioning and reduce possible residual pressures (e.g. non-return valves, stopcocks and similar).
2. Loosen and remove all screws evenly or unscrew the STARK.basic Y with the mounting key.
3. The 2 screw countersinks each have a thread. A set screw must first be screwed into each of the two threaded bores under the countersinks so that the threaded bore cannot be damaged by the pressure of the jack screw. Then press the STARK.basic evenly out of the fit using the two jack screws (this point is not necessary for STARK.basic Y).

6 Commissioning, handling and operation

6.1 Initial commissioning

- Carry out a visual inspection of the entire machine and the fast closing clamps
- Remove any unauthorised persons from the vicinity of the machine
- Check the fast closing clamp for pneumatic tightness
- Check the release pressure

6.2 Function check

- If all clamping elements connected to the same circuit are installed as described above and tightened with the appropriate torque, the pneumatic pressure generator can be connected to the circuit.
- Release: Slowly and carefully increase the pneumatic pressure to the release pressure. When doing so, check the clamping elements for leaks, switch off the pressure generator immediately if necessary and eliminate the leakage.
- Switch on the blow-out air and check that enough air is flowing out of the nozzle. Check the nozzle for ease of movement.
- The supply line must be checked for leaks during the seat check query.

6.3 Operation



The speed when retracting the retractable nipples into the fast clamping elements must be less than 100 mm/s, otherwise the retractable nipples and fast clamping elements may be damaged.



Only pressurise the fast closing clamp for the pallet change process.

Do not leave under permanent pressure (released)!

- Set the release pressure of the fast clamping clamps (see chapter "8 Technical data")
- Monitor the max. operating pressure of the fast closing clamps. Set the excess pressure safety valve to max. 5 bar above the max. operating pressure (see chapter "8 Technical data")

6.4 STARK.basic with blow-out function and seat check



Blowing out and blowing off produces flying chips!

Provide suitable protective measures, e.g. safety goggles, cover, safety door, etc.

Ensure sufficient air supply (see chapter "8 Technical data").

- Switch on the blow-out air first; this must remain activated during the entire feeding process
- Release the STARK.basic after approx. 3 seconds.
- Change pallet
- Clamp the STARK.basic
- Only now switch off the blow-out air and switch to the seat check
- Start the machine if the seat check is successful

7 Maintenance and servicing

7.1 Function check



Check the STARK.basic for proper function: Check the retraction of all balls when the STARK.basic is released.



If the retractable nipple cannot be pushed into the locating bore and removed without force, a service at STARK Spannsysteme GmbH is required immediately. If no service is performed, safe clamping of the retractable nipple is not possible. There is a risk of accident!

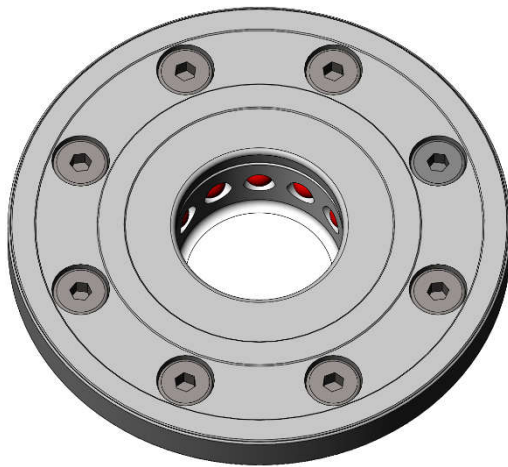

Monthly:

Check that all balls retract when the fast clamping system is released.

Yearly or after 5000 clamping cycles:

Check all functions of the fast clamping element. If one or more functions are no longer in perfect working order, servicing by STARK Spannsysteme GmbH is necessary immediately.

7.2 Spring assembly maintenance interval

When the clamping cycles or replacement intervals have been reached, the fast closing clamp must be serviced by STARK Spannsysteme GmbH (see chapter "8 Technical data" Spring assembly maintenance interval).

Please contact us to coordinate the service work:

Tel.: +43 5522 37 400

Mail: info@stark-roemheld.com

7.3 Cleaning

No contamination is permitted in the fast closing clamp. Cleaning depends on the application and replacement interval.



Widespread practice!

The fast closing clamp may be blown out and off with compressed air.



Correct and improved!

Extraction and suction of chips, dirt and coolant from the fast closing clamp.



7.4 General cleaning

For general cleaning, the fast closing clamp must be dismantled. Assembly work may only be carried out by STARK Spannsysteme GmbH. The necessary safety measures must be observed in their entirety and without exception during all work.



Hazard information: The fast closing clamp is permanently under spring pressure! Do not open the housing. There is a risk of personal injury or material damage!

The product may not be cleaned with:



- corrosive or caustic components
- organic solvents such as halogenated or aromatic hydrocarbons and ketone (nitro thinner, acetone etc.) These could destroy the seals.

The element must be cleaned at regular intervals. In particular, the area of bore, ball holder and housing must be cleaned of chips and other liquids. In case of heavy contamination, cleaning must be carried out at shorter intervals.

7.5 Storage

Until first use:

If you do not use the fast closing clamp immediately, please store it dry and dust-free in its original packaging.

Long period of storage after use:

Before storage, clean the fast closing clamp (see chapter "7.4 General cleaning") and carry out suitable measures for corrosion protection.

After a long period of storage:

After a long period of storage (approx. 3 years), the seals must be replaced before the system is used again. This must always be done by STARK Spannsysteme GmbH.





7.6 Disposal/recycling

All parts, auxiliary materials and process media of the fast clamping device must be separated according to type and disposed of in accordance with the local regulations and directives.



Hazard information: The fast closing clamp is permanently under spring pressure! Do not open the housing. There is a risk of personal injury or material damage!

8 Technical data

		STARK.basic.Y	STARK.basic.S	STARK.basic.M
				
Spring assembly maintenance interval		80,000	80,000	80,000
Retention force 1)	[N]	1500	5,000	9,000
Air release pressure	[bar]	4.5	5.5-6	4-4.5
max. pressure	[bar]	10	10	10
Air volume	[cm ³]	1.6	4.5	12
Operating temperature	[°C]	10-80	10-80	10-80
Min. permitted clamping time	[s]	1	1	1
Min. permitted release time	[s]	1	1	1
Radial pre-positioning ²⁾	[mm]	± 1	± 1	± 1
Max. axial pre-positioning	[mm]	- 0.3	- 0.3	- 0.3
Repeat accuracy ³⁾	[mm]	< 0.01	< 0.01	< 0.01
Weight	[kg]	approx. 0.06	approx. 0.5	approx. 1.5

¹ **Retention force:** This is the maximum overload at which the nipple is still held but has already left the zero point.

² **Radial pre-positioning:** The loading device must be powerless and flexible for manual and automated loading.

³ **Repeat accuracy:** This usually indicates the accuracy that refers to the change of the same pallet position-oriented on the same interface.



9 Declaration of Incorporation

This document refers to the Declaration of Incorporation according to Machinery Directive 2006/42/EC Annex II No. 1 letter B:

Manufacturer: **STARK Spannsysteme GmbH**
Römergrund 14
A-6830 Rankweil
Austria

Authorised representative to compile the technical documentation:

Mr. Martin Greif, Managing Director, address: See manufacturer.

Product: Fast closing clamp
Function: Clamping and centring of workpiece pallets, machine elements or system elements
Product group: STARK.basic
Article number: 8000 001 - 8000 ...
Trade name/
general designation: Fast closing clamp

The manufacturer undertakes to provide the specific technical documentation relating to the incomplete machinery to national authorities in electronic or written form upon justified request.

Before it is established that the complete machine complies with the provisions of the Machinery Directive 2006/42/EC, it is prohibited to put the incomplete machinery into service.

If applicable, there are additional guidelines for the machine integrator, among others, to observe and implement completely and correctly before commissioning:

EN ISO 12100; EN ISO 4413

- in the respective valid version of the legally prescribed date.

STARK Spannsysteme GmbH

Rankweil, 13/10/2023

Martin Greif
Managing Director / Geschäftsführer



The following part of the Declaration of Incorporation according to the Machinery Directive 2006/42/EC Annex II No. 1 letter B describes which parts of the Machinery Directive 2006/42/EC have already been fulfilled for the system used at the time of handover of the product(s) or still have to be fulfilled subsequently by the integrator of the complete machine. The list is drawn up in accordance with the Machinery Directive 2006/42/EC Annex I.

If a superordinate provision is marked and the sub-items are not indicated, this shall apply collectively to all subordinate provisions which are thus to be fulfilled or have already been fulfilled.

If individual aspects are not relevant to the system described in this document by the manufacturer or distributor, this does NOT necessarily mean that the integrator of the complete machine does not have to consider these aspects in general.

If two columns are marked, this means that parts of the provisions have already been partially or fully complied with, but the integrator is responsible for full compliance.

				To be fulfilled by the system integrator:	↓
				Fulfilled on the part of the system manufacturer:	↓
				Not relevant:	↓
1.			Essential health and safety requirements		
1.1.			General remarks		
1.1.1.			Definitions		X X
1.1.2.			Principles of safety integration		X X
1.1.3.			Materials and products		X X
1.1.4.			Lighting		X
1.1.5.			Design of a machinery product to facilitate its handling		X X
1.1.6.			Ergonomics		X
1.1.7.			Operating positions		X
1.1.8.			Seating		X
1.2.			Control systems		X
1.3.			Protection against mechanical hazards		
1.3.1.			Risk of loss of stability		X
1.3.2.			Risk of break-up during operation		X
1.3.3.			Risks due to falling or ejected objects		X
1.3.4.			Risks due to surfaces, edges or angles		X
1.3.5.			Risks related to combined machinery		X
1.3.6.			Risks related to variations in operating conditions		X
1.3.7.			Risks related to moving parts		X
1.3.8.			Choice of protection against risks arising from moving parts		X
1.3.8.1.			Moving transmission parts		X
1.3.8.2.			Moving parts involved in the process		X
1.3.9.			Risks of uncontrolled movements		X
1.4.			Required characteristics of guards and protective devices		X
1.5.			Risks due to other hazards		
1.5.1.			Power supply		X
1.5.2.			Static electricity		X
1.5.3.			Power supply other than electricity		X
1.5.4.			Errors of fitting		X X
1.5.5.			Extreme temperatures		X
1.5.6.			Fire	X	
1.5.7.			Explosion	X	
1.5.8.			Noise		X
1.5.9.			Vibrations	X	



1.5.10.			Radiation	X		
1.5.11.			External radiation	X		
1.5.12.			Laser radiation	X		
1.5.13.			Emissions of hazardous materials and substances			X
1.5.14.			Risk of being trapped in a machine			X
1.5.15.			Risk of slipping, tripping or falling			X
1.5.16.			Lightning	X		
1.6.			Maintenance			X
1.7.			Information			
1.7.1.			Information and warnings on the machinery product		X	X
1.7.1.1.			Information and information devices			X
1.7.1.2.			Warning devices			X
1.7.2.			Warning of residual risks			X
1.7.3.			Marking of machinery			X
1.7.4.			Instructions		X	X
1.7.4.1.			General principles for the drafting of instructions		X	X
1.7.4.2.			Content of the instructions		X	X
1.7.4.3.			Sales literature		X	X
2.			Supplementary essential health and safety requirements for certain categories of machinery products			X
3.			Supplementary essential health and safety requirements to offset risks due to the mobility of machinery			X
4.			Supplementary essential health and safety requirements to offset hazards due to lifting operations			X
5.			Supplementary essential health and safety requirements for machinery products intended for underground work			X
6.			Supplementary essential health and safety requirements for machinery products presenting particular risks due to the lifting of persons			X



Alle derzeit verfügbaren Sprachen finden Sie unter:

All currently available languages can be found at:

<https://www.stark-roemheld.com/download>