

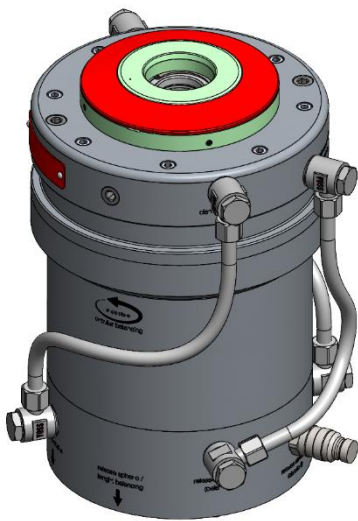

STARK.spheric zero point clamping system

Translation of the original operating manual

WM-020-456-10-en BA STARK.spheric.docx



*STARK.spheric
NP R1/R2*

Art. no.: S801-260 (R1)

Art. no.: S801-261 (R2)

Art. no.: S801-264 (R1)

Art. no.: S801-265 (R2)

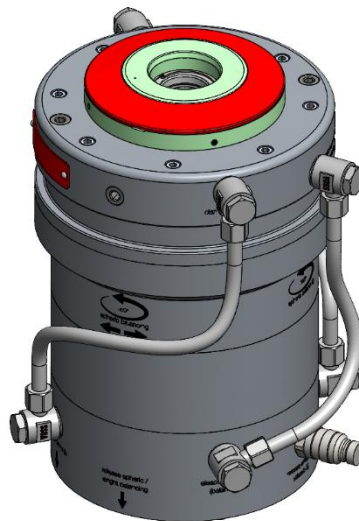

*STARK.spheric
AG*

Art. no.: S801-262

Art. no.: S801-266

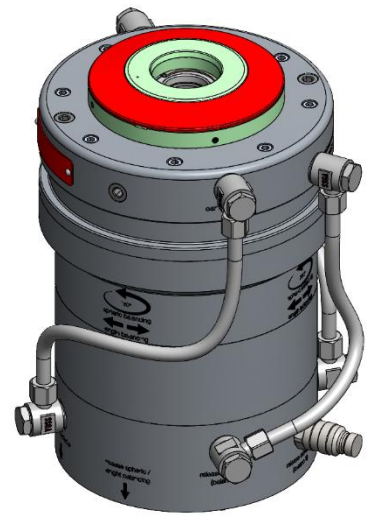

*STARK.spheric
OZ*

Art. no.: S801-263

Art. no.: S801-267

Manufacturer:

STARK Spannsysteme GmbH
Römergrund 14
6830 Rankweil
Austria
+43 5522 37 400
info@stark-roemheld.com
www.stark-roemheld.com



1 Table of contents

1	Table of contents	2
2	Identification of the partly completed machinery	4
3	User instructions	4
3.1	Purpose of the document	4
3.2	Revision history	4
3.3	Referenced documents	4
3.4	Presentation of safety instructions	5
4	Essential safety instructions	6
4.1	Intended use.....	6
4.2	Foreseeable misuse.....	6
4.3	When using rotating machine tools.....	6
4.4	Modifications or alterations	6
4.5	Conduct in the event of faults.....	6
4.6	Spare and wear parts and auxiliary materials	6
4.7	Obligations of the operating company.....	7
4.8	Residual risks.....	7
4.8.1	Spring assembly.....	7
4.8.2	Workpiece change procedure and fast clamping device	7
4.8.3	Hydraulic system malfunction.....	7
4.8.4	Danger due to incorrect installation of the retractable nipple	8
4.8.5	Danger due to changes in rotational speed	8
4.8.6	Excess pressure hazards	8
4.8.7	Hazard due to exhaust air noise.....	8
4.8.8	Influences on service life	8
5	Description of the fast clamping device	9
5.1	General.....	9
5.2	Design versions.....	10
5.2.1	STARK.spheric NP R1 (with zero point for 2x clamping)	10
5.2.2	STARK.spheric NP R2 (with zero point for 3x clamping)	10
5.2.3	STARK.spheric AG (with equaliser function)	11
5.2.4	STARK.spheric OZ (without centring)	11
5.3	Structure of STARK.spheric (MD connection)	12
5.4	Structure of STARK.spheric (side connection)	13
6	Assembly and installation	14
6.1	STARK.spheric (MD connection)	14
6.2	STARK.spheric (side connection)	15
7	Commissioning, handling and operation	16
7.1	During initial commissioning.....	16
7.2	Function check.....	16
7.3	Operation.....	16
7.4	Preventing damage to components	16
7.5	Lubricants and oils (hydraulic oil).....	16
8	Sequence diagram.....	17



8.1	STARK.spheric assembly / disassembly	17
8.2	STARK.spheric function	18
9	Maintenance and repair	19
9.1	Surface cleaning.....	19
9.2	General cleaning	19
9.3	Storage:.....	19
9.4	Disposal/recycling:	19
10	Technical data	19
11	Declaration of Incorporation.....	22



2 Identification of the partly completed machinery

Product: fast clamping device
Function: clamping and centring of workpieces
Product group: STARK.spheric
Article number: S801-260 to S801-267
Trade name: Corresponds to product group, see above

3 User instructions

3.1 Purpose of the document

This operating manual

- describes the function, operation and maintenance of the fast clamping device
- gives important instructions for safe and efficient use of the fast clamping device

3.2 Revision history

Date	Revision	Name
12/08/2025	Creation of the operating manual	mafr

3.3 Referenced documents

Document	Version	Author
Assembly drawings with parts lists (data sheets)	-	Stark Spannsysteme GmbH
OM STARK.classic.NG	WM-020-332-xx-xx	Stark Spannsysteme GmbH
OM STARK.balance	WM-020-369-xx-xx	Stark Spannsysteme GmbH
OM Media duct NW4	WM-020-149-xx-xx	Stark Spannsysteme GmbH
OM Insertion force tester	WM-020-133-xx-xx	Stark Spannsysteme GmbH
OM Specification dimension tester	WM-020-349-xx-xx	Stark Spannsysteme GmbH



3.4 Presentation of safety instructions

Safety instructions are identified by a pictogram. The illustration of the pictograms with signal word is shown. The signal word describes the severity of the impending risk.



DANGER

Immediate imminent risk to life and health of persons (serious injury or death).

Be sure to follow these notes and procedures!



CAUTION

Potentially dangerous situation (minor injuries or damage to property).

Be sure to follow these notes and procedures!



INFORMATION

Tips for use and particularly useful information.



INSTRUCTION

Obligation for special conduct or an activity for the safe handling of the machine.

4 Essential safety instructions

4.1 Intended use



The fast clamping device is used for clamping workpieces.

The workpieces are intended for processing and measuring.

Intended use also presupposes:

- compliance with all the instructions in the operating manual
- observance of the inspection and maintenance intervals
- use of only OEM parts.

4.2 Foreseeable misuse



Any other use than or beyond that specified in the chapter 4.1 "Intended use" is considered improper use!

Risks may occur if the product is not used as intended. Examples of improper use include:

- exceeding the technical values specified for normal operation
- application for hoist operation and load transportation
- use as tool holder
- use as pressing tool
- disregard of the safety guidelines according to EC Machinery Directive 2006/42/EC

The operating company bears sole responsibility for any injury or damage resulting from such improper use. The manufacturer assumes no liability.

4.3 When using rotating machine tools



For rotating applications, the fast clamping device may only be operated if it is ensured that it is securely clamped. It must also be ensured that the permissible forces acting on the fast closing clamp are not exceeded according to the technical data.

Specialists must be consulted for the calculation and design of the fast clamping devices for rotating applications. Stark provides this service.

4.4 Modifications or alterations



Unauthorised modifications or alterations of the fast clamping device will void any liability and warranty on the part of the manufacturer!

Therefore, do not make any changes or additions to the fast clamping device without consultation and written consent of the manufacturer.

4.5 Conduct in the event of faults



- Stop operation immediately
- Report fault to the responsible personnel
- Have the fault rectified only by qualified personnel
- Check products and machine for safe operation

4.6 Spare and wear parts and auxiliary materials



Only retractable nipples from STARK may be used on the workpiece and must be installed according to the appropriate STARK data sheet.

The use of spare and wear parts from third-party manufacturers can result in risks. Use only OEM parts or parts approved by the manufacturer. The manufacturer will assume no liability for any injury or damage resulting from the use of spare and wear parts and auxiliary materials not approved by the manufacturer.

4.7 Obligations of the operating company



The operating company is obliged to allow only persons to work on the fast clamping device who

- are familiar with the fundamental occupational health and safety and accident prevention regulations.
- have been instructed in the use of the fast clamping device and have read and understood this operating manual.

The requirements of EC Directive 2007/30/EC on the use of work equipment must be observed.

4.8 Residual risks



Attention must be paid to the existence of mechanical, hydraulic and pneumatic residual energies at the fast clamping device and the pressure in the cylinders and valves after switching off the fast clamping device!

For example:

- preloaded springs
- pressure locked in by non-return valve
- pressure locked in by valve lock position
- etc.

4.8.1 Spring assembly



If the fast closing clamp is dismantled improperly, the pre-tensioned spring assembly or other parts may be slung away. For exact procedure, see WM-020-332-xx-xx and WM-020-369-xx-xx.

4.8.2 Workpiece change procedure and fast clamping device



To ensure safe positioning on the fast clamping device, make sure there is a grip point for the hand. If this grip point is not structurally possible, care must be taken when fitting so that hand/fingers are never between the fast clamping device and the nipple or between the fast clamping device and the workpiece.

When clamping, do not reach with your fingers into the gap between the fast closing clamp and the workpiece.

4.8.3 Hydraulic system malfunction



During operation, a malfunction in the hydraulics may cause an unintentional increase in pressure and consequently release the fast clamping device. Particularly in rotating applications, this can result in a hazardous situation.

Possible measures to prevent accidental release:

- Mechanically disconnecting the hydraulic line (uncoupling). This means that a pressure increase is no longer possible during operation.
- Disconnecting the safety valves from the machine hydraulics. This means that a pressure increase is no longer possible during operation.
- Pressure monitoring in the release circuit of the fast closing clamp. This causes the emergency stop to be triggered when the pressure rises, resulting in an immediate stop of the machine.

4.8.4 Danger due to incorrect installation of the retractable nipple



Improper tightening of the fixing screws or insufficient strength of the screws may cause the retractable nipple to come loose.



The risk potential is considerably higher for rotating applications.

Measure:

The installation instructions regarding strength class, tightening torque, and arrangement must be observed (see data sheets supplied) and chapter 6 "Assembly and installation".

4.8.5 Danger due to changes in rotational speed



Excessive rotational speed, weight and unbalance can cause the fast closing clamp to break, resulting in the workpiece being catapulted away.

Measure:

Observe the information and regulations regarding the maximum values of Stark. (see chapter 10 "Technical data")

4.8.6 Excess pressure hazards



Lines or hoses bursting due to excessive pressures can endanger persons.

Measure:

- Protect hydraulic lines with pressure relief valves.
- Observe the specified pressure limits.

4.8.7 Hazard due to exhaust air noise



Loud noises can be generated by the pneumatics.

Measure:

- Wear ear protection

4.8.8 Influences on service life

Negative influences include:



- Insufficient filtering of the oil; observe filter mesh size < 15µ.
- External mechanical damage to functional components.
- Undefined forces or defined forces exceeded.
- Insufficient ventilation of the hydraulic circuit.
- Overloading due to sudden pressure peaks.
- Too high volume flow rates / piston speeds due to large pump capacity.
- Heavy contamination (e.g. casting or grinding dust).
- Aggressive environment, e.g. cooling lubricants which chemically attack seals / wipers.
- Incorrect pre-clamping position or loading position.

5 Description of the fast clamping device

5.1 General

The **STARK.spheric** impresses with its combination of active insertion, degree of freedom-controlled pendulum and length compensation, and precise zero point clamping. These functions ensure distortion-free clamping of workpieces – even with complex geometries and changing clamping conditions.

The fast clamping device forms the interface between the machine and the workpiece and serves to significantly speed up the setup process. While one workpiece is being machined, the next one can be prepared at the same time. Clamping is carried out directly via the fast closing clamp.

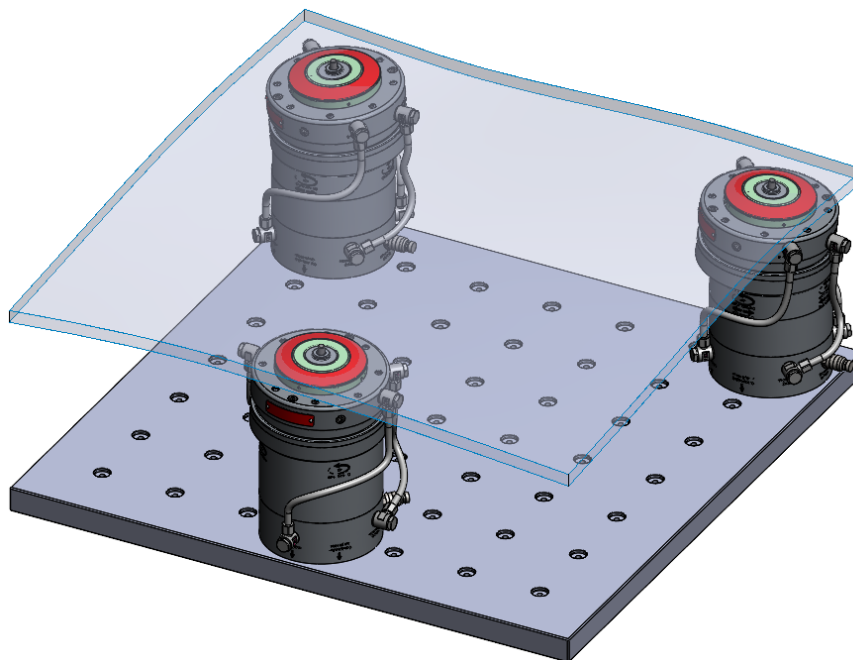

Application example - 3x clamping example

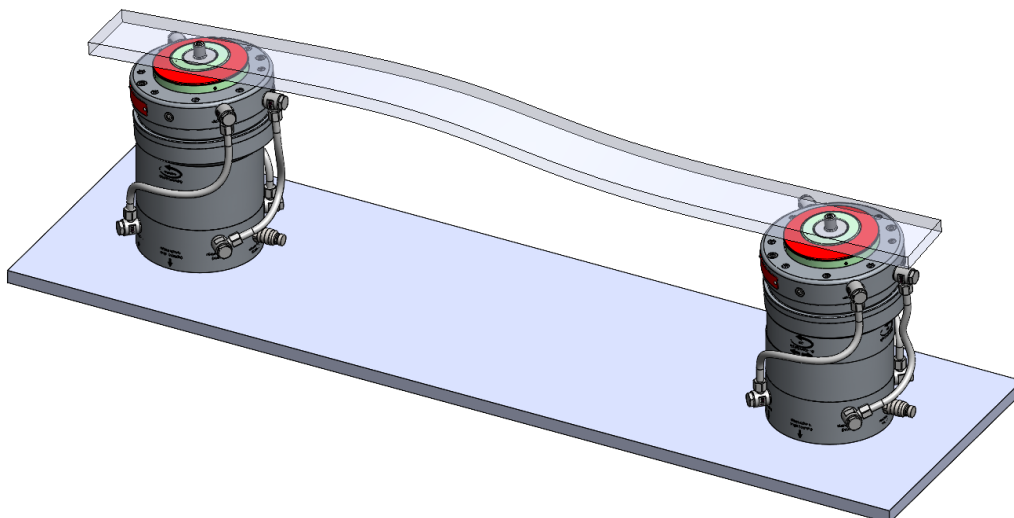

Application example - 2x clamping example



5.2 Design versions

5.2.1 STARK.spheric NP R1 (with zero point for 2x clamping)

Art. no.: **S801-260** with zero point, pendulum compensation of $\pm 5^\circ$ in **one direction**, without changing the zero point in the position. Connections via media duct on the underside.



Art. no.: **S801-264** with zero point, pendulum compensation of $\pm 5^\circ$ in **one direction**, without changing the zero point in the position. Connections via couplings on the side.



5.2.2 STARK.spheric NP R2 (with zero point for 3x clamping)

Art. no.: **S801-261** with zero point, pendulum compensation of $\pm 5^\circ$ in **all directions**, without changing the zero point in the position. Connections via media duct on the underside.



Art. no.: **S801-265** with zero point, pendulum compensation of $\pm 5^\circ$ in **all directions**, without changing the zero point in the position. Connections via couplings on the side.



5.2.3 STARK.spheric AG (with equaliser function)

Art. no.: **S801-262** with equaliser function, pendulum compensation of $\pm 5^\circ$ in **all directions** and length compensation of $\pm 1.5\text{mm}$ in **one direction**. Connections via media duct on the underside.



Art. no.: **S801-266** with equaliser function, pendulum compensation of $\pm 5^\circ$ in **all directions** and length compensation of $\pm 1.5\text{mm}$ in **one direction**. Connections via couplings on the side.



5.2.4 STARK.spheric OZ (without centring)

Art. no.: **S801-263** without centring, pendulum compensation of $\pm 5^\circ$ in **all directions** and length compensation of $\pm 1.5\text{mm}$ in **all directions**. Connections via media duct on the underside.



Art. no.: **S801-267** without centring, pendulum compensation of $\pm 5^\circ$ in **all directions** and length compensation of $\pm 1.5\text{mm}$ in **all directions**. Connections via couplings on the side.





5.3 Structure of STARK.spheric (MD connection)

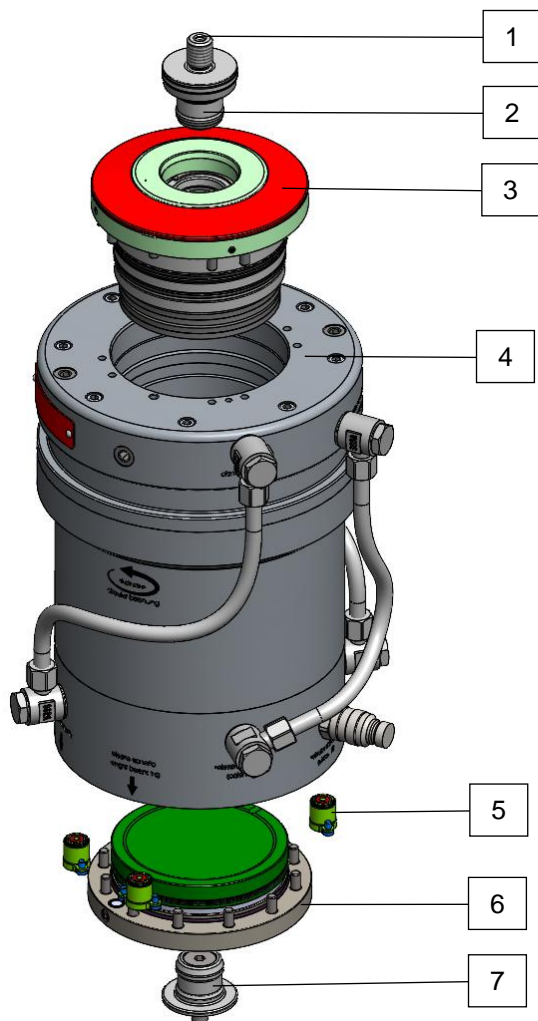

- | | |
|----|---|
| 1 | Connection to the workpiece
(Screw connection situation) |
| 2 | Stark.balance.2 NP retractable nipple for
direct clamping |
| 3 | STARK.balance.2 NP (S801-207)
(see OM: WM-020-369-xx-xx) |
| 4 | STARK.spheric (MD connection) (pendulum
compensation, length compensation) |
| 5 | 4x media ducts (S704-201)
(see OM: WM-020-149-xx-xx) |
| 6 | STARK.classic.2.NG (S804-538)
(see OM: WM-020-332-xx-xx) |
| 7 | Retractable nipple STARK.classic.2 |
| 8 | Connection: Clamp control input |
| 9 | Connection: Loosen STARK.spheric |
| 10 | Connection: Loosen STARK.classic.2.NG |
| 11 | Connection: Clamp control output |

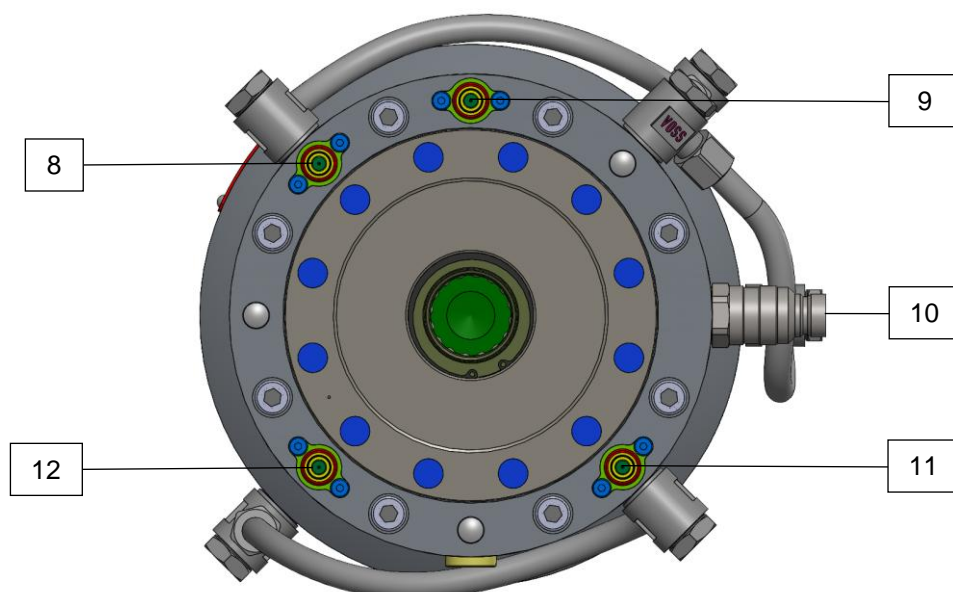



5.4 Structure of STARK.spheric (side connection)

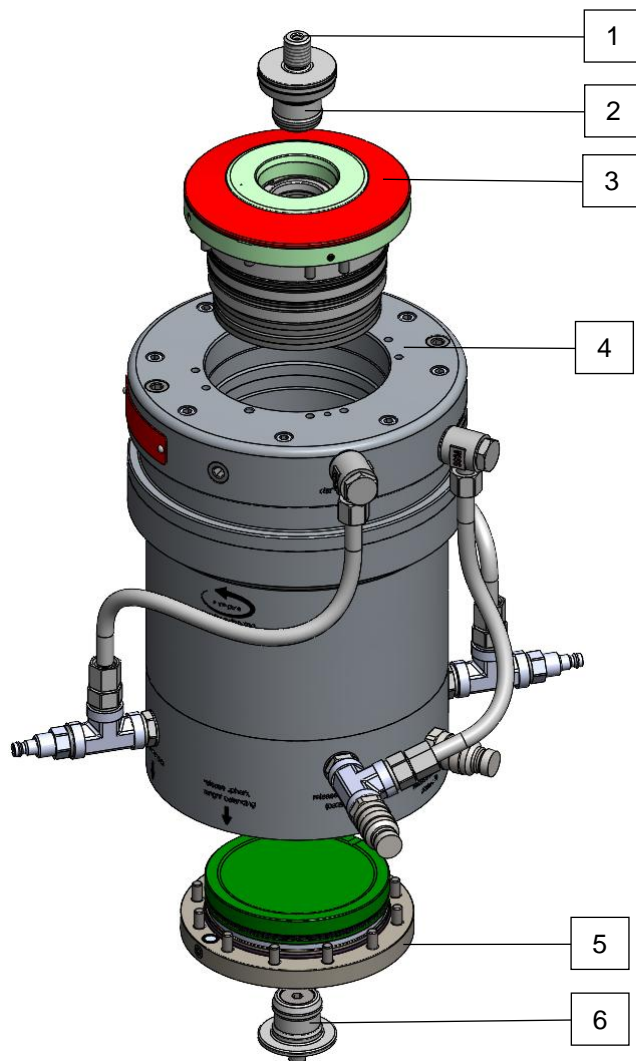

- 1 Connection to the workpiece (Screw connection situation)
- 2 Stark.balance.2 NP retractable nipple for direct clamping
- 3 STARK.balance.2 NP (S801-207) (see OM: WM-020-369-xx-xx)
- 4 STARK.spheric (side connection) (pendulum compensation, length compensation)
- 5 STARK.classic.2.NG (S804-538) (see OM: WM-020-332-xx-xx)
- 6 Retractable nipple STARK.classic.2

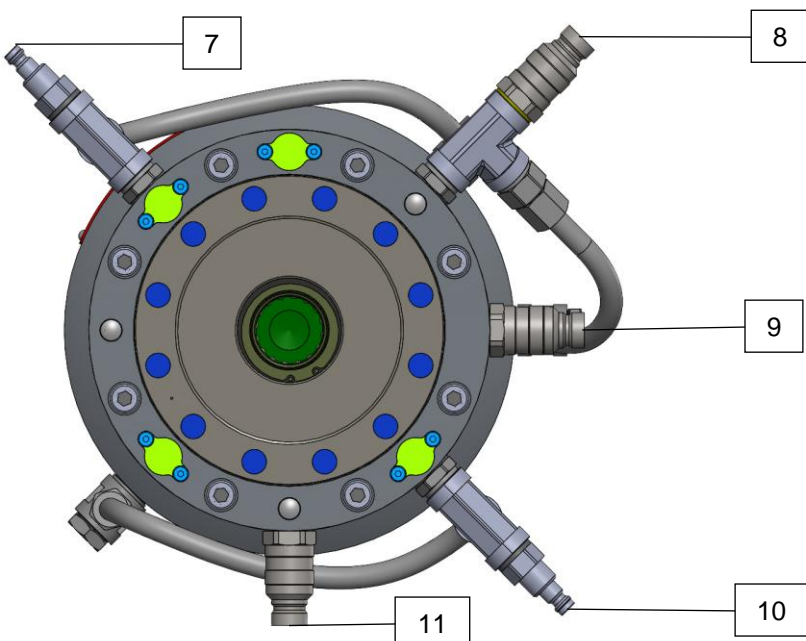



6 Assembly and installation

6.1 STARK.spheric (MD connection)

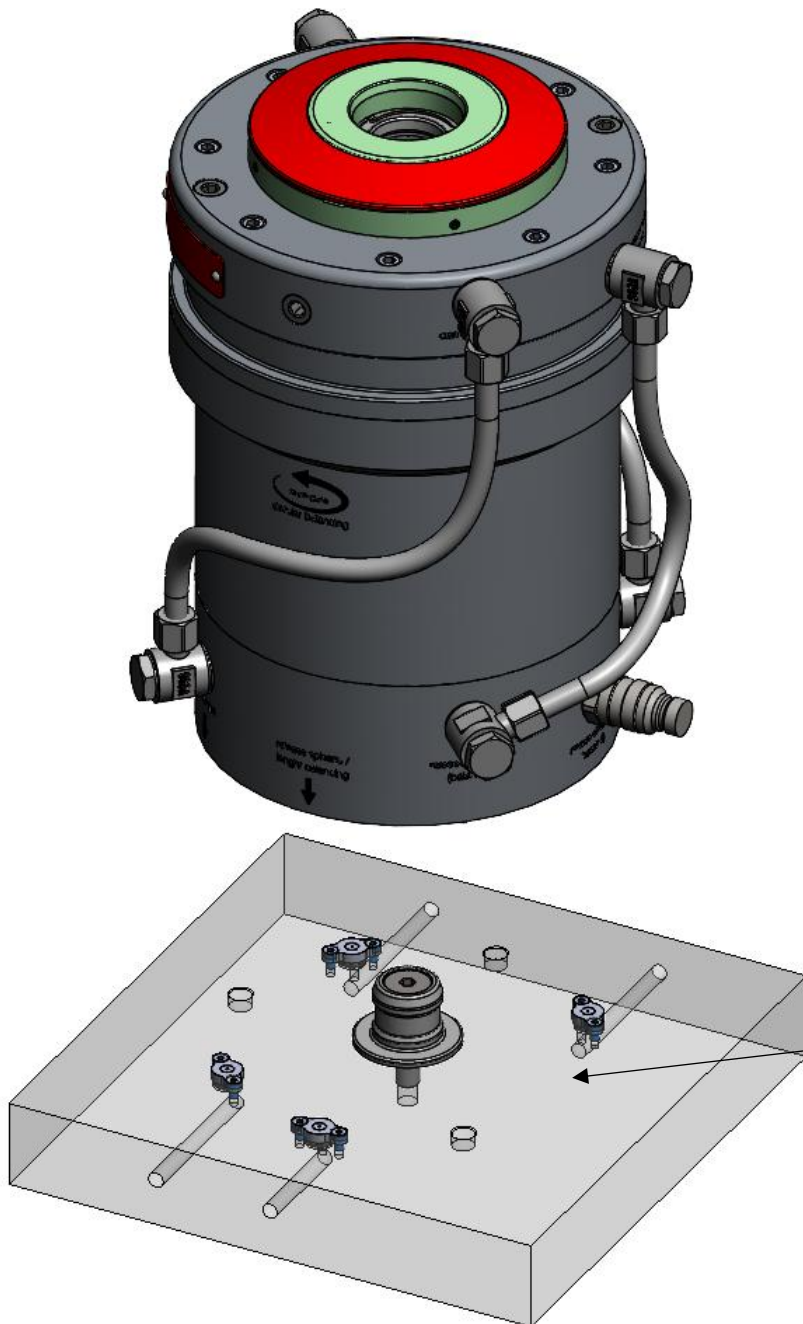

Installation according to data sheet D200

(MD4 connection)

1x retractable nipple NP
STARK.classic 2
Art. no.: S804-470

1x screw M10x50
10.9 DIN 7991
Art. no.: S931-506
Tightening torque: 45 Nm

4x MD NW4
Coupling mechanism ABV
Art. no.: S704-200
Tightening torque: 2.5 Nm



6.2 STARK.spheric (side connection)

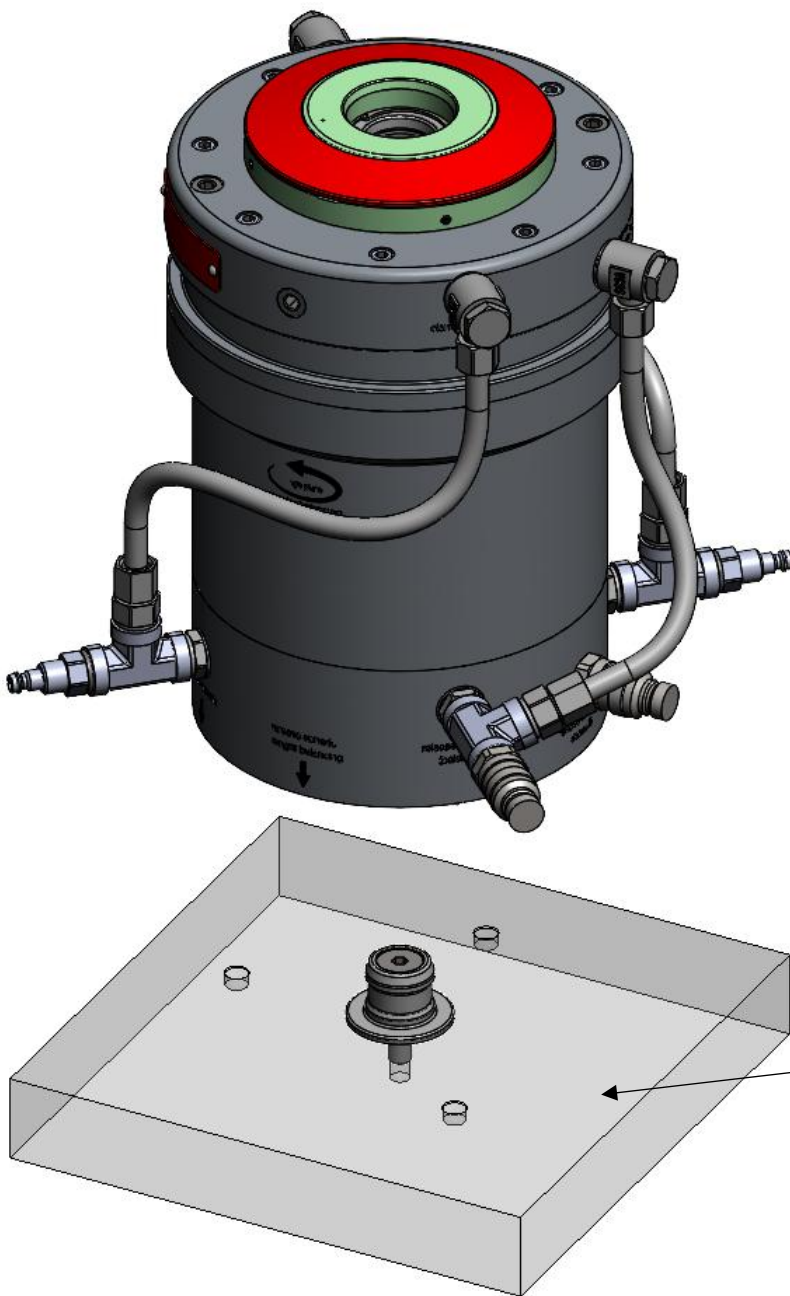

Installation according to data sheet D200 (side connection)

1x retractable nipple NP STARK.classic 2
Art. no.: S804-470

1x screw M10x50
10.9 DIN 7991
Art. no.: S931-506
Tightening torque: 45 Nm

7 Commissioning, handling and operation

7.1 During initial commissioning

- Perform a visual inspection of the entire machine and/or system and the fast clamping device.
- Check the fast clamping device for hydraulic and pneumatic tightness.
- Check the release pressure of the fast closing clamp. (Clamping time/release time min. 2 sec.)

7.2 Function check

- Once all fast closing clamps are connected to the same circuit, the hydraulic pressure generator can be connected to the circuit and the circuit can be vented.
- Release: Slowly and carefully increase the hydraulic pressure to the release pressure. (clamping time/release time min. 2 sec.). When doing so, check the fast closing clamps for leaks, switch off the pressure generator immediately if necessary and eliminate the leakage.

7.3 Operation



The speed when retracting the retractable nipples into the fast closing clamps must be less than 100 mm/s, otherwise the retractable nipples and fast closing clamps may be damaged.



Only pressurise the fast closing clamp for the actual change procedure.
Do **not** leave under permanent pressure (released)!

- Set the release pressure of the fast closing clamps (see chapter 10 "Technical data")
- Monitor the max. operating pressure of the fast closing clamps. Set the excess pressure safety valve to max. 5 bar above the max. operating pressure (see chapter 10 "Technical data")



In order to ensure that the elements function permanently, the appropriate **air quality** must be provided. STARK's data therefore refer to a purity according to ISO 8573-1:2010 [7:4:4].

7.4 Preventing damage to components

The product must not be cleaned with:



- corrosive or caustic materials or
- organic solvents such as halogenated or aromatic hydrocarbons and ketones (nitro-cellulose thinner, acetone, etc.) as these can destroy the seals.

The fast closing clamps must be kept clean and cleaned immediately if soiled. In particular, the areas of the piston or housing, support surfaces and centring hole must be cleaned of chips and other liquids.

In case of heavy contamination, cleaning must be carried out at shorter intervals.

7.5 Lubricants and oils (hydraulic oil)



Unsuitable lubricants and oils can damage the seals and will drastically shorten the service life.
CAUTION: Mixing of oils is not permitted.

Recommendation: Hydraulic oil "Castrol Hyspin AWS 32" or "Castrol Hyspin AWS 46"

8 Sequence diagram

8.1 STARK.spheric assembly / disassembly

Time sequence for assembly / disassembly of STARK.spheric:

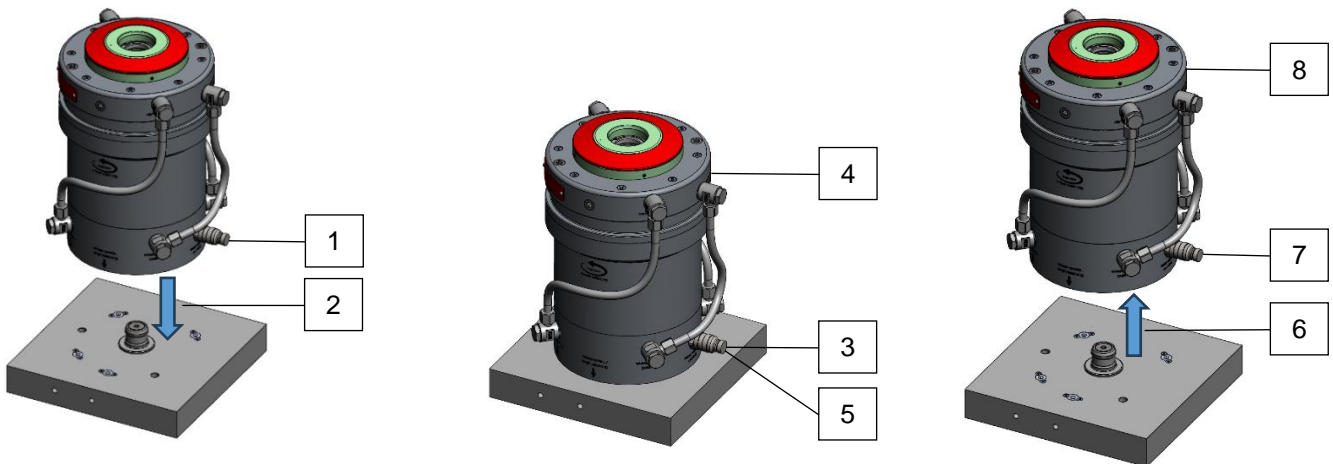
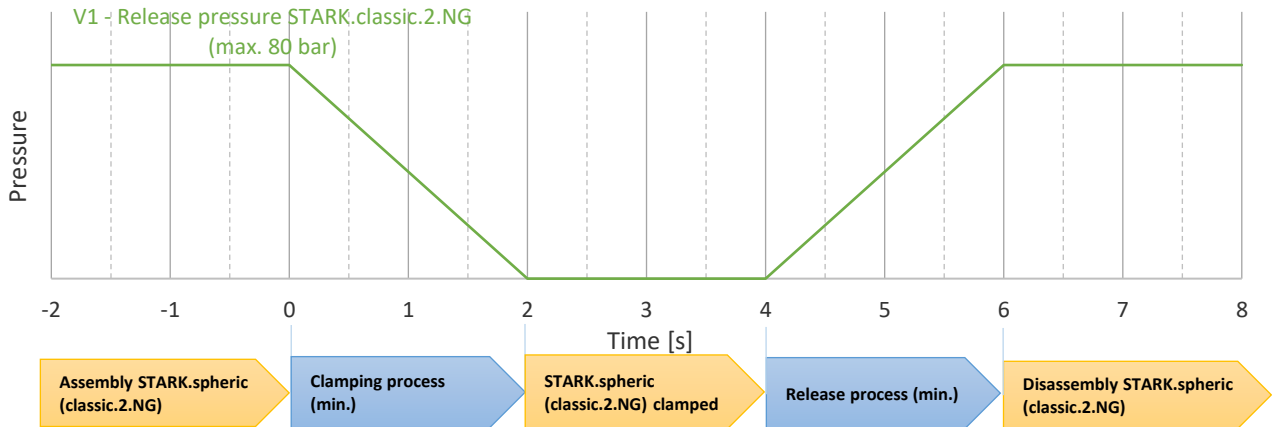

- 1 Loosen STARK.classic.2.NG
Release pressure: (min. 40 bar, max. 80 bar)
- 2 Attach STARK.spheric
- 3 Switch STARK.classic.2.NG clamping to depressurised
- 4 STARK.spheric fixed (clamped)
- 5 Loosen STARK.classic.2.NG
Release pressure: (min. 40 bar, max. 80 bar)
- 6 Take off STARK.spheric
- 7 Switch STARK.classic.2.NG to unpressurised
- 8 Store STARK.spheric

8.2 STARK.spheric function

Time sequence of the release process STARK.spheric:

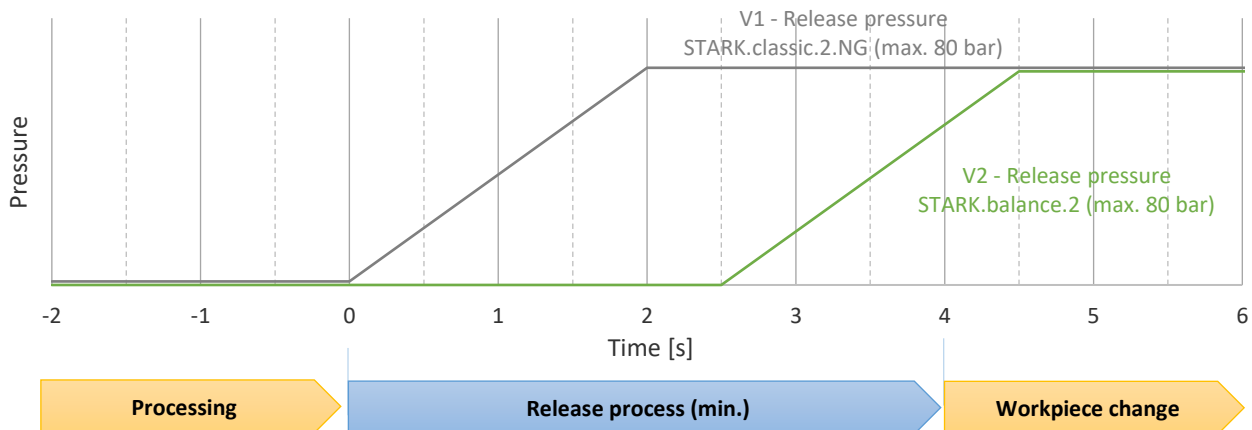

Release process:

1. STARK.spheric - loosen
2. STARK.balance.2 - loosen
3. Workpiece change

Time sequence of the clamping process STARK.spheric:

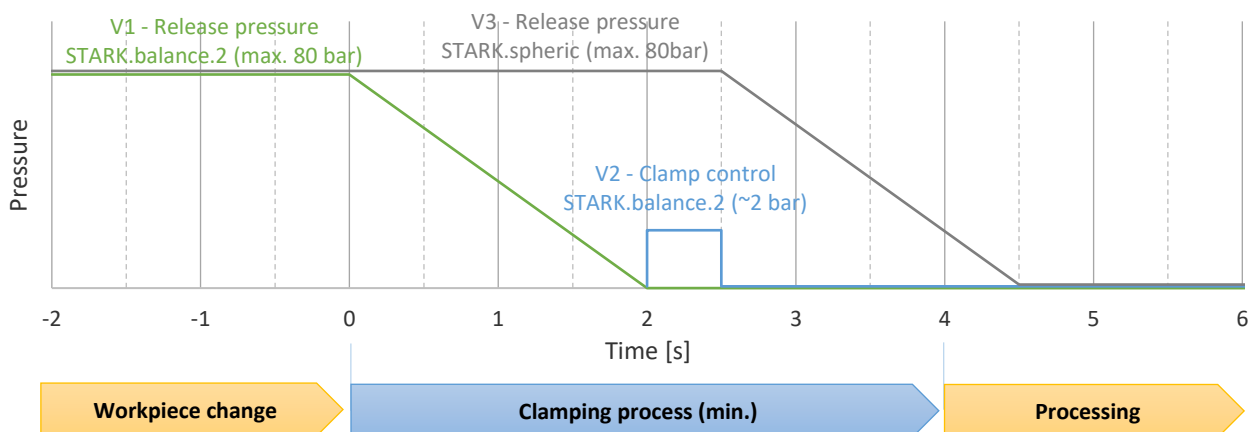

Clamping process:

1. Workpiece change
2. STARK.balance.2 - depressurised
3. Clamp control - switch on
4. Clamp control - OK
5. STARK.spheric - depressurised
6. Processing

9 Maintenance and repair

9.1 Surface cleaning

No contamination is permitted in the fast closing clamp. Cleaning depends on the application and replacement interval.



Widespread practice!

The fast closing clamp may be blown out and off with compressed air.



Correct and better!

Extraction and suction of chips, dirt and coolant from the fast closing clamp.



9.2 General cleaning

For general cleaning, the fast closing clamp must be dismantled. Assembly work may only be carried out by STARK Spannsysteme GmbH. The necessary safety measures must be observed in their entirety and without exception during all work.



Hazard information: The fast closing clamp is permanently under spring pressure! Do not open the housing. There is a risk of personal injury or material damage!

The product must not be cleaned with:



- corrosive or caustic components
- organic solvents such as halogenated or aromatic hydrocarbons and ketone (nitro thinner, acetone etc.) These substances would destroy the seals.

The element must be cleaned at regular intervals. In particular, the area of bore, ball holder and housing must be cleaned of chips and other liquids. In case of heavy contamination, cleaning must be carried out at shorter intervals.

9.3 Storage:

Until first use:

If you do not use the fast clamping device immediately, please store it dry and dust-free in its original packaging.

Long period of storage after use:

Before storage, clean the fast clamping device (see chapter 9.2 "General cleaning" and take measures for corrosion protection.

After a long period of storage:

After a long period of storage (approx. 3 years), replace the O-rings before use.

9.4 Disposal/recycling:

All parts, auxiliary materials and process media of the fast clamping device must be separated according to type and disposed of in accordance with the local regulations and directives.



Hazard information: The fast closing clamp is permanently under spring pressure! Do not open the housing. There is a risk of personal injury or material damage!

10 Technical data



Designation:	STARK.spheric NP R1 MD4	STARK.spheric NP R2 MD4	STARK.spheric AG MD4	STARK.spheric OZ MD4
Art. no.:	S801-260	S801-261	S801-262	S801-263
Drawing number	028-000	028-001	028-002	028-003
Pendulum compensation function (one direction)	±5°	-	-	-
Pendulum compensation function (all directions)	-	±5°	±5°	±5°
Length compensation function (one direction)	-	-	± 1.5 mm	-
Length compensation function (all directions)	-	-	-	± 1.5 mm
Pendulum compensation min. / max. release	60 bar / 80 bar			
Length compensation min. / max. release	-	-	60 bar / 80 bar	60 bar / 80 bar
System accuracy	< 0.015 mm			
Max. lateral forces	5 kN / 1000 Nm			
Installation according to data sheet	D200			
Media duct NW4 operating manual	WM-020-149-xx-xx			
Temperature range	+10°C to 80°C			
Dimensions	ø202mm x 300mm (305mm / cylinder pins)			
Weight	28 kg			
Fast closing clamps	STARK.classic.2.NG		STARK.balance.2	
Insertion force ¹	22 kN		20 kN	
Retention force ²	38 kN			
Max. release pressure ³	80 bar			
Min. release pressure ⁴	40 bar		60 bar	
Lifting power	13.9 kN (50 bar) / 21.7 kN (60 bar)		10 kN (70 bar) / 15 kN (80 bar)	
Retraction path / lifting path	1.2 mm			
Oil volume	40 cm ³		22 cm ³	
Min. permitted clamping / release time	2 sec.			
Maintenance cycles ⁵	40,000			
Hydraulic oil	according to DIN 51524 (HLP 32 or HLP 46)			
Filter class	Quality class 4			
Sealing material	NBR; other materials on request			
Operating manual	WM-020-332-xx-xx		WM-020-369-xx-xx	

¹ Insertion force will fall below this value with increasing clamping cycles. The insertion force (pre-tensioning force of the spring assembly) is the load up to which the zero point is guaranteed. The permissible deviation of the insertion force is ±15%.

² This is the maximum overload at which the retractable nipple is still held but the zero point has already been left.

³ Set the excess pressure safety valve to max. 5 bar above the max. release pressure.

⁴ Only pressurise the fast closing clamp for the change procedure - do not leave it pressurised for a longer period of time.

⁵ Only under optimal conditions



Designation:	STARK.spheric NP R1 side connection	STARK.spheric NP R2 side connection	STARK.spheric AG side connection	STARK.spheric OZ side connection
Art. no.:	S801-264	S801-265	S801-266	S801-267
Drawing number	028-004	028-005	028-006	028-007
Pendulum compensation function (one direction)	±5°	-	-	-
Pendulum compensation function (all directions)	-	±5°	±5°	±5°
Length compensation function (one direction)	-	-	± 1.5 mm	-
Length compensation function (all directions)	-	-	-	± 1.5 mm
Pendulum compensation min. / max. release	60 bar / 80 bar			
Length compensation min. / max. release	-	-	60 bar / 80 bar	60 bar / 80 bar
System accuracy	< 0.015 mm			
Max. lateral forces	5 kN / 1000 Nm			
Installation according to data sheet	D200			
Temperature range	+10°C to 80°C			
Dimensions	ø202mm x 300mm (305mm / cylinder pins)			
Weight	28 kg			
Fast closing clamps	STARK.classic.2.NG		STARK.balance.2	
Insertion force ⁶	22 kN		20 kN	
Retention force ⁷	38 kN			
Max. release pressure ⁸	80 bar			
Min. release pressure ⁹	40 bar		60 bar	
Lifting power	13.9 kN (50 bar) / 21.7 kN (60 bar)		10 kN (70 bar) / 15 kN (80 bar)	
Retraction path / lifting path	1.2 mm			
Oil volume	40 cm ³		22 cm ³	
Min. permitted clamping / release time	2 sec.			
Maintenance cycles ¹⁰	40,000			
Hydraulic oil	according to DIN 51524 (HLP 32 or HLP 46)			
Filter class	Quality class 4			
Sealing material	NBR; other materials on request			
Operating manual	WM-020-332-xx-xx		WM-020-369-xx-xx	

⁶ Insertion force will fall below this value with increasing clamping cycles. The insertion force (pre-tensioning force of the spring assembly) is the load up to which the zero point is guaranteed. The permissible deviation of the insertion force is ±15%.

⁷ This is the maximum overload at which the retractable nipple is still held but the zero point has already been left.

⁸ Set the excess pressure safety valve to max. 5 bar above the max. release pressure.

⁹ Only pressurise the fast closing clamp for the change procedure - do not leave it pressurised for a longer period of time.

¹⁰ Only under optimal conditions



11 Declaration of Incorporation

This document refers to the Declaration of Incorporation according to Machinery Directive 2006/42/EC Annex II No. 1 letter B:

Manufacturer: **STARK Spannsysteme GmbH - Römergrund 14 - 6830 Rankweil - Austria**

Authorised representative to compile the technical documentation:
Mr. Martin Greif, Managing Director, address: See manufacturer.

Product:	fast clamping device
Function:	clamping and centring of workpieces
Product group:	STARK.spheric
Article number:	S801-260 to S801-267
Trade name/ general designation:	Fast closing clamp

The manufacturer undertakes to provide the specific technical documentation relating to the incomplete machinery to national authorities in electronic or written form upon justified request.

Before it is established that the complete machine complies with the provisions of the Machinery Directive 2006/42/EC, it is prohibited to put the incomplete machinery into service.

If applicable, there are additional guidelines for the machine integrator, among others, to observe and implement completely and correctly before commissioning:
EN ISO 12100; EN ISO 4413
- in the respective valid version of the statutory date.

Stark Spannsysteme GmbH

Rankweil, 12/08/2025

Martin Greif
Managing Director / Geschäftsführer



The following part of the Declaration of Incorporation according to the Machinery Directive 2006/42/EC Annex II No. 1 letter B describes which parts of the Machinery Directive 2006/42/EC have already been fulfilled for the system used at the time of handover of the product(s) or still have to be fulfilled subsequently by the integrator of the complete machine. The list is drawn up in accordance with the Machinery Directive 2006/42/EC Annex I.

If a superordinate provision is marked and the sub-items are not indicated, this shall apply collectively to all subordinate provisions which are thus to be fulfilled or have already been fulfilled.

If individual aspects are not relevant to the system described in this document by the manufacturer or distributor, this does NOT necessarily mean that the integrator of the complete machine does not have to consider these aspects in general.

If two columns are marked, this means that parts of the provisions have already been partially or fully complied with, but the integrator is responsible for full compliance.

				To be fulfilled by the system integrator:		↓
				Fulfilled on the part of the system manufacturer:	↓	
				not relevant:	↓	
1.			Essential health and safety requirements			
1.1.			General remarks			
1.1.1.			Definitions		X	X
1.1.2.			Principles of safety integration		X	X
1.1.3.			Materials and products		X	X
1.1.4.			Lighting			X
1.1.5.			Design of machinery to facilitate its handling		X	X
1.1.6.			Ergonomics			X
1.1.7.			Operating positions			X
1.1.8.			Seating			X
1.2.			Control systems			X
1.3.			Protection against mechanical hazards			
1.3.1.			Risk of loss of stability			X
1.3.2.			Risk of break-up during operation		X	
1.3.3.			Risks due to falling or ejected objects			X
1.3.4.			Risks due to surfaces, edges or angles		X	
1.3.5.			Risks related to combined machinery			X
1.3.6.			Risks related to variations in operating conditions			X
1.3.7.			Risks related to moving parts			X
1.3.8.			Choice of protection against risks arising from moving parts			X
1.3.8.1.			Moving transmissions parts			X
1.3.8.2.			Moving parts involved in the process			X
1.3.9.			Risk of uncontrolled movements			X
1.4.			Required characteristics of guards and protective devices			X
1.5.			Risks due to other hazards			
1.5.1.			Electricity supply			X
1.5.2.			Static electricity			X
1.5.3.			Energy supply other than electricity			X
1.5.4.			Errors of fitting		X	X
1.5.5.			Extreme temperatures			X
1.5.6.			Fire	X		
1.5.7.			Explosion	X		



1.5.8.		Noise			X
1.5.9.		Vibrations	X		
1.5.10.		Radiation	X		
1.5.11.		External radiation	X		
1.5.12.		Laser radiation	X		
1.5.13.		Emissions of hazardous materials and substances			X
1.5.14.		Risk of being trapped in a machine			X
1.5.15.		Risk of slipping, tripping or falling			X
1.5.16.		Lightning			X
1.6.		Maintenance			X
1.7.		Information			
1.7.1.		Information and warnings on the machinery		X	X
1.7.1.1.		Information and information devices			X
1.7.1.2.		Warning devices			X
1.7.2.		Warning of residual risks			X
1.7.3.		Machinery marking			X
1.7.4.		Instructions		X	X
1.7.4.1.		General principles for the drafting of instructions		X	X
1.7.4.2.		Content of the instructions		X	X
1.7.4.3.		Sales literature		X	X
2.		Supplementary essential health and safety requirements for certain categories of machinery			X
3.		Supplementary essential health and safety requirements to offset hazards due to the mobility of machinery			X
4.		Supplementary essential health and safety requirements to offset hazards due to lifting operations			X
5.		Supplementary essential health and safety requirements for machinery intended for underground work			X
6.		Supplementary essential health and safety requirements for machinery presenting particular hazards due to the lifting of persons			X